

City of Plainwell



Brad Keeler, Mayor
Lori Steele, Mayor Pro-Tem
Todd Overhuel, Council Member
Roger Keeney, Council Member
Randy Wisnaski, Council Member

Department of Administration Services
211 N. Main Street
Plainwell, Michigan 49080
Phone: 269-685-6821 Fax: 269-685-7282
Web Page Address: www.plainwell.org

“The Island City”

AGENDA

Plainwell City Council
Monday, September 26, 2022 - 7:00PM
Plainwell City Hall Council Chambers

1. Call to Order
2. Invocation
3. Pledge of Allegiance
4. Roll Call
5. Approval of Minutes – 09/12/2022 Regular Meeting
6. General Public Comments
7. County Commissioner Report
8. Agenda Amendments
9. Mayor’s Report
10. Recommendations and Reports:
 - A. DDA/BRA/TIFA – Hick’s Park Sound System
Council will consider approving a contract with BC Sound for a sound system in Hick’s Park in the amount of \$8,368.97.
 - B. WR – 12th St Lift Station Pump Purchase
Council will consider approving a contract with JGM Valve for the purchase of two new pumps for the 12th St Lift Station in the amount of \$35,698.00.
 - C. DPW – City Tree Removal
Council will consider approving a contract with Blankenship Logging to remove city trees in the amount of \$16,600.00.
 - D. Resolution 2022-17 – Approved Depositories for 2022
Council will consider adopting the resolution listing the approved depositories for city funds.
11. Communications: The August Water Renewal report, and the draft 9/13/2022 DDA/BRA/TIFA meeting minutes, and the draft 9/15/2022 Parks & Trees meeting minutes.
12. Accounts Payable - \$150,612.97
13. Public Comments
14. Staff Comments
15. Council Comments
16. Adjournment

Note: All public comment limited to two minutes, when recognized please rise and give your name and address.

MINUTES
Plainwell City Council
September 12, 2022

1. Mayor Keeler called the regular meeting to order at 7:00 PM in City Hall Council Chambers.
2. The invocation was given by Scott Fenner of Lighthouse Baptist Church.
3. Pledge of Allegiance was given by all present.
4. Roll Call: Present: Mayor Keeler, Mayor Pro Tem Steele, Councilmember Overhuel, and Councilmember Wisnaski. Absent: Keeney.
A motion by Steele, seconded by Overhuel, to excuse Councilmember Keeney from the proceedings. On a voice vote, all voted in favor. Motion passed.
5. Approval of Minutes:
A motion by Steele, seconded by Overhuel, to accept and place on file the Council Minutes of the 08/22/2022 regular meeting. On a voice vote, all voted in favor. Motion passed.
6. Public Comment: William Geresy, 543 6th St, spoke on a potential model train museum and how it would help the City of Plainwell and proposed a meeting between the model train owner and the City of Plainwell.
7. County Commissioner Report: None.
8. Agenda Amendments: None.
9. Mayor's Report: Mayor Keeler offered to have Allegan County Clerk/Register Bob Genetski present his report under the Mayor's Report.
Clerk/Register Genetski presented the annual report and provided an update on the Clerk and Register of Deeds offices. He also recognized the City of Plainwell Election Inspectors and thanked them for their work.
10. Recommendations and Reports:
 - A. Clerk Fenger and Finance Director/Treasurer Kelley introduced the Election Inspectors and spoke regarding the work they do each year for the City. They presented certificates to all the inspectors and thanked them for the wonderful job they do.
 - B. Manager Wilson reported that a zoning variance request had been submitted for the proposed Holiday Inn Express located at 371 12th St, Parcel A. The zoning ordinance allows for 3 stories but Holiday Inn Express is normally 4 stories. The hearing would be set for October 10 at 7pm.
A motion by Steele, seconded by Overhuel, to set a public hearing for 7:00pm on October 10, 2022 to receive comments regarding a zoning variance request for 371 12th St Parcel A. On a voice vote, all voted in favor. Motion passed.

- C. Manager Wilson reported that the proposed policy was part of the requirements for using Community Development Block Grant funding. He noted the policy would affect only the projects using CDBG funding.

A motion by Wisnaski, seconded by Steele, to approve the policy regarding residential displacement and relocation. On a roll call vote, all voted in favor. Motion passed.

- D. Superintendent Pond reported on the need to monitor the process in the anerobic digesters, and explained the need for the emergency purchase due to the length of time it would take to get new parts. These level detectors allow accurate readings, and being unable to accurately read the levels in the digesters would be a safety issue.

A motion by Overhuel, seconded by Wisnaski, to confirm an emergency purchase from Oudbier Instrument Co. to install, service and calibrate the level detectors for the anerobic digesters in the amount of \$8,400.00. On a roll call vote, all voted in favor. Motion passed.

- E. Superintendent Pond reported the current boiler heat exchanger sludge tubes had been installed in 2005 and had buildup accumulate over the years that stopped the heat transfer from working. The company that installed the tubes informed him that there was no way to clean them, and the only way to address the issue was to replace the tubes. He noted that he had saved certain spare parts from the first installation which saved approximately \$700 on the installation cost because those parts could be used now.

A motion by Wisnaski, seconded by Steele, to approve a contract with Evoqua for the purchase of 12 new tubes and freight in the amount of \$9,702.36. On a roll call vote, all voted in favor. Motion passed.

- F. Personnel Manager Lamorandier reported on the changes made to the job descriptions to accurately reflect the staffing changes. With her retirement, duties were being moved to other roles, so the Personnel Manager position was becoming the Personnel Coordinator position, and the Treasurer position was becoming the Finance Director/Treasurer position.

A motion by Steele, seconded by Overhuel, to approve the amended job descriptions in the Administration Department. On a voice vote, all voted in favor. Motion passed.

- G. Clerk Fenger reported that she had worked with Personnel Manager Lamorandier, Finance Director/Treasurer Kelley, and Personnel Coordinator Kersten to create the new employee recognition policy that offered a single day off for each milestone instead of logo-wear pieces for each milestone. Personnel Manager Lamorandier noted that as more departments started wearing logos on their every-day work clothes, offering the logo-wear as an award had less appeal.

Clerk Fenger noted that the policy had been brought as a first read, so no action was required at this time.

Councilmember Steele proposed voting on the policy now since none of the Councilmembers had any changes they wished to make to the policy.

A motion by Steele, seconded by Wisnaski, to approve the employee recognition policy as presented. On a voice vote, all voted in favor. Motion passed.

- H. Clerk Fenger reported that the current office phones were not supported by any vendor and had not been for several years. She reported seeking quotes from 5 vendors, however 2 responded. Moss was the closest vendor, and had offered to reduce their installation fee from \$3,250 to \$1,500. She noted

that this was a 37 month contract, with 1 month free from Moss, and this contract would decrease the monthly bill for the office phones by approximately \$80. Clerk Fenger noted that the contract cost included the monthly bill that the city already budgeted for, as well as the installation and other upfront cost. She also reported that this phone system upgrade would allow departments to transfer calls between buildings which is not currently possible with the existing system.

A motion by Wisnaski, seconded by Overhuel, to approve a contract with Moss to upgrade the city office phone system to a leased, managed system in the amount of \$25,811.70. On a roll call vote, all voted in favor. Motion passed.

- I. Finance Director/Treasurer Kelley reported that a budget encumbrance was a housekeeping item that brought purchases budgeted for the previous year but not yet completed into the current budget year. He noted that the spring had been busy, and there were 18 projects that had been budgeted in 2022 and needed to be brought forward to 2023.

A motion by Steele, seconded by Overhuel, to approve a budget amendment for the 2021/2022 purchases rolled over to the current budget. On a roll call vote, all voted in favor. Motion passed.

11. Communications:

A motion by Steele, seconded by Overhuel, to accept and place on file the August 2022 Investment and Fund Balance reports, the August Department of Public Safety report and the draft 8/17/2022 Planning Commission meeting minutes. On a voice vote, all voted in favor. Motion passed.

12. Accounts Payable:

A motion by Wisnaski, seconded by Steele, that the bills be allowed and orders drawn in the amount of \$743,637.36 for payment of same. On a roll call vote, all voted in favor. Motion passed.

13. Public Comments: William Geresy announced that the Furniture City Tournament will happen this Saturday, September 17, at the Fortress of Solitude and he invited everyone to attend.

14. Staff Comments:

Finance Director/Treasurer Kelley reported that the auditors would be on site next week, and the new part-time accounts payable clerk had started last week.

Personnel Manager Lamorandier reported continued work on cleaning, moving, and training.

Superintendent Pond reported the regional intermunicipal sewer meeting had been held recently, and an issue had been identified with the 12th Street lift station. He noted that more information would be coming soon.

Director Callahan reported that the Director's car had been sold through a sealed bid auction, and the winning bid was \$3,126.01. He reported on the radar speed signs and explained that for the most part, the speeds being reported were within acceptable ranges of the posted speed limits.

Clerk Fenger reported working on a new event to try and draw in more election inspectors. She noted the event would be held on September 27 at 6pm and would include a short presentation overview of election

worker duties, a question and answer session, and hands-on time with the election equipment. She encouraged anyone interested in becoming an election inspector to attend and encouraged everyone present to share the information about the event. She thanked the election workers again for their dedication and service.

Manager Wilson reported receiving some interest from 2 parties regarding the William Crispe House and potential uses for it. He asked Councilmembers what direction they wanted to go in with the William Crispe House.

Councilmembers directed Manager Wilson to put the William Crispe House back on the city's web page for more interested parties to view, and directed him to reach out to the two existing interested parties for more information on their proposed projects.

15. Council Comments:

Councilmember Wisnaski thanked the poll workers for their hard work and dedication.

Councilmember Steele thanked the poll workers for doing what they do, and thanked Clerk Fenger and Finance Director/Treasurer Kelley for their work training the poll workers. She also thanked DPW for their work picking up brush throughout the city. She wished a happy birthday to Finance Director/Treasurer Kelley, Personnel Manager Lamorandier and Clerk Fenger.

Councilmember Keeler noted that he had not known Personnel Manager Lamorandier's birthday was this month as well as everyone else's, so he wished her a happy birthday as well.

Councilmember Overhuel wished everyone a happy birthday, and thanked the poll workers for their hard work.

16. Adjournment:

A motion by Steele, seconded by Overhuel, to adjourn the meeting at 8:16 PM. On a voice vote, all voted in favor. Motion passed.

Minutes respectfully
Submitted by,
Margaret Fenger
City Clerk

MINUTES APPROVED BY CITY COUNCIL
September 26, 2022

Margaret Fenger, City Clerk



“The Island City”

MEMORANDUM

211 N. Main Street
Plainwell, Michigan 49080
Phone: 269-685-6821
Fax: 269-685-7282

TO: City Council
FROM: Erik Wilson, City Manager
DATE: May 6, 2022
SUBJECT: Hick’s Park Sound System

The DDA BRA TIFA board has made a recommendation to purchase a sound system for Hick’s Park, in the amount of \$8,368.97. Three quotes were received. BC Sound is the most expensive quote but, they are local, they visited the site to assess the needs of the park and this price includes installation of the speakers and training for staff on how to use the portable system. The DDA BRA TIFA budget has \$15,000 in the capital purchase line item to cover the cost of this system.

Hick’s Park is used for many special events with large numbers of participants. By installing the speakers on Soule Fountain and a quality portable system will increase the range of the sound throughout the park.

Sound System Quotes

Company	Total Cost	Training/Install	Timeframe	Reference
Pro Acoustics (Texas)	7,035.40	No	Shipping times vary and are not guaranteed	
Sweetwater (Ft. Wayne, IN)	\$5,201.19	No	Ships 1 -2 businesses days after order. Speaker wire is on backorder 2/3 weeks	Could not give me specific references but they have worked with municipalities
BC Sound (Springfield, MI)	\$8,368.97	Yes (\$2,040.00) Included in price	Hard to nail down, would provide a loaner system but they hope it would all be in by Nov.	City of Battle Creek and City of Portage
Mercury (Wixom, MI)	\$400 for a site visit to quote. Easily well over \$10,000			Detroit, Ann Arbor, Grand Rapids, Southfield

BC Sound
2775 West Dickman Rd.
STE - H3
Springfield, Mi 49037

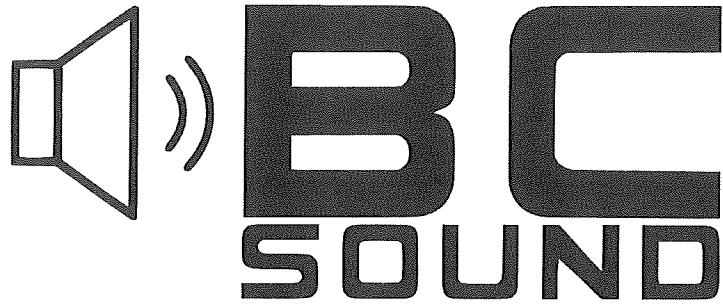

Proposal: Park Audio System

Prepared for:

City of Plainwell

Prepared by:

Matt Kaynor

on

August 31, 2022

Project 1284 1.0

ABOUT US

BC Sound

For over 20 years BC Sound / K2AVL has provided Audio, Video, Lighting and Staging to clients throughout lower Michigan. Whether its an Installation, Event, or Rental, we have you covered. With countless system designs and installations like the ones below, you know you can count on us to bring your project to life.

Let us help you create a system you will enjoy using for years to come.

BC Sound's Office is located at 2775 West Dickman Rd STE H3, Springfield MI 49037

269 965 7500



Our Story

For over 20 years BC Sound, Audio Visual Services has provided Audio, Video, Lighting and Staging to clients throughout lower Michigan. We provide Audio/Visual Installation, Sales and Service, Training, Corporate AV Events, Outdoor Festivals and Events.



Our Passion

We enjoy not only installing AV Systems, but also provide Sound, Lighting, and Video for corporate events, outdoor events and festivals. We know how to use the equipment and will help you understand your installed system and provide training to you and your team whenever you need it..



Our Team

Our friendly staff will listen to your needs to make sure you get a system that you will enjoy using for years to come. We will also be there for service whenever you need us.

-- Kellogg Arena Recently Installed

Proposal Overview

We have designed this system to allow for expansion as the needs grow.

This phase will have three high-power Community 70-volt speakers mounted to the soffit of the gazebo. One will cover the southeast, one will cover the street and the third will cover the park. In the future, additional speakers can be added to cover deeper down the street and into the park. A speaker jack will be installed inside the gazebo.

The equipment will be kept in a rolling rack. This rack will contain a mixer, media player with CD-Aux Cable-USB-Bluetooth-AM/FM Tuner, a receiver for a handheld wireless microphone, a drawer for the microphone and cables to be stored in, the amplifier, and a digital sound processor.

When in use the rack will have a speaker cable that will connect it to the speakers on the gazebo.

BC Sound / K2AVL



Springfield MI 49037
 t. 269-965-7500 f. 269-288-2440
 BCProSound.com
 Matt@BCProSound.com

Confidential Proposal

PARK**LABOR**

IMAGE	QTY	DESCRIPTION	PRICE	PRICE EXT	LABOR EXT
	1	BC Sound Labor Labor/Programming/Rigging/Training/Wiring/Testing	\$0.00	\$0.00	\$2,040.00
LABOR TOTAL					\$2,040.00

SPEAKERS

IMAGE	QTY	DESCRIPTION	PRICE	PRICE EXT	LABOR EXT
	3	Community Professional Loudspeakers R.25-94TZ Full-Range 2-Way 8-Inch 90 X 40 Grey 70V/100V	\$870.00	\$2,610.00	\$0.00
	50	West Penn Wire 225 16 Gauge Installation Speaker Wire	\$0.40	\$20.00	\$0.00
	1	BC Sound Misc Parts and Connectors Cables and fittings	\$100.00	\$100.00	\$0.00
SPEAKERS TOTAL					\$2,730.00

PORTABLE RACK



IMAGE	QTY	DESCRIPTION	PRICE	PRICE EXT	LABOR EXT
	1	Elite Core RC12U-20 OSP RC12U-20 12 Space ATA Amp Case w/Casters	\$599.99	\$599.99	\$0.00
	1	Denon Professional DN-312X 12-Channel Line Mixer with Priority	\$199.00	\$199.00	\$0.00
	1	Peavey VSX 26E	\$499.99	\$499.99	\$0.00
	1	Denon Professional DN-300Z CD, SD, USB Player with BT and AM/FM Receiver, Single Play, Balanced Outputs	\$449.00	\$449.00	\$0.00
	1	Audio Technica ATW-3212/C510DE2 3000 Series Wireless System (4th gen) includes: ATW-R3210 receiver and ATW-T3202 handheld transmitter with ATW-C510 cardioid dynamic microphone capsule, 470-530 MHz	\$599.99	\$599.99	\$0.00

1.0 August 31, 2022

BC Sound / K2AVL

Springfield MI 49037
 t. 269-965-7500 f. 269-288-2440
 BCProSound.com
 Matt@BCProSound.com

Confidential Proposal

IMAGE	QTY	DESCRIPTION	PRICE	PRICE EXT	LABOR EXT
	1	BC Sound Custom Interface Plate Custom Interface Plate 3 - XLR Inputs 3 - Speaker Outputs	\$150.00	\$150.00	\$0.00
	1	Furman M-8X2 15A Standard Power Conditioner, 9 Outlets, 1RU, 6Ft Cord	\$120.00	\$120.00	\$0.00
	1	Penn Elcom 3232lk 2 RK Rack Drawer	\$75.00	\$75.00	\$0.00
	1	BC Sound Misc Parts and Connectors Cables and fittings	\$100.00	\$100.00	\$0.00
	1	BC Sound / K2AVL Used Amplifier QSC CX 302V	\$500.00	\$500.00	\$0.00

PORTABLE RACK TOTAL	\$3,292.97
----------------------------	-------------------

EQUIPMENT TOTAL	\$6,022.97
------------------------	-------------------

PARK TOTAL	\$8,062.97
-------------------	-------------------

BC Sound / K2AVL

2775 West Dickman Rd. STE H3
Springfield MI 49037
t. 269-965-7500 f. 269-288-2440
BCSound.com

Confidential Proposal

ACCEPTANCE

ACCEPTANCE

PAYMENT SCHEDULE

60% down to order equipment and get started. Balance on completion. (Prices reflect a 4% cash, check, or money order discount, If paying by credit card, please add 4% to the total amount.)

If the job is of a retrofit/remodel nature on an existing structure, and the scope of work exceeds time estimated to complete because of unforeseen circumstances, the owner agrees that he/she will be back-charged at a rate of \$85 per man, per hour for all extra labor involved in completing the job.

EQUIPMENT TOTAL	\$6,022.97
SHIPPING TOTAL	\$306.00
<hr/>	
LABOR TOTAL	\$2,040.00
<hr/>	
SUBTOTAL	\$8,368.97
TOTAL SALES TAX	\$0.00
PROJECT TOTAL	\$8,368.97

TERMS

I accept this proposal and hereby authorize BC Sound / K2AVL to proceed with the installation of the included systems at the facilities of City of Plainwell constructing at , as described in the totality of this document. I further authorize BC Sound / K2AVL to be granted the facility access that will be required to complete this project in a workmanlike and timely manner and for payment to be made to BC Sound / K2AVL. In keeping with the Terms of Payment listed above. It has been made clear to me that there exist no understandings regarding this project with any relevant party unless and until City of Plainwell and BC Sound / K2AVL agree to such additional or alternate understandings in writing. Project cost and pricing are dependent upon a continual flow of work without interruption or delays imposed by City of Plainwell or their staff, construction, other building trades or any other party, and additional costs may be incurred by City of Plainwell from BC Sound / K2AVL. If such delays result in additional costs that are not covered by the pricing in this proposal. I agree that any additions to and/or deletions from the materials and labor to be provided by my acceptance of this proposal and any resulting change(s) in cost of this project shall only be by way of written change order(s) and shall be valid only after being signed by City of Plainwell and BC Sound / K2AVL. BC Sound will also remove replaced equipment items as salvage. Installations have full factory warranty on all installed products. This proposal is valid only if accepted in writing by City of Plainwell and deposit payment received no later than September 30, 2022.

ACCEPTANCE

CITY OF PLAINWELL

SIGNED

Denise Siegel

PRINT NAME

BC SOUND / K2AVL

DATE

TITLE

SIGNED

PRINT NAME

DATE

TITLE



Brad Keeler, Mayor
Lori Steele, Mayor Pro-Tem
Roger Kenney, Council Member
Todd Overhuel, Council Member
Randy Wisnaski, Council Member
www.plainwell.org

Bryan D. Pond, Superintendent
129 Fairlane Street
Plainwell, Michigan 49080
Phone: 269-685-5153
Fax: 269-685-1994
Email: BPond@plainwell.org

TO: Erik J. Wilson, City Manager
FROM: Bryan Pond, Superintendent
DATE: 9/14/2022
SUBJECT: Approval for Purchase of Two New Pumps 12th St. Lift Station

For several years the pumps at 12th St pump station have been frequently plugging with clothing, towels, and non-flushable wipes. With increased service calls and pump down time I felt the need to upgrade the pumps to a "chopper cutter" style pump to alleviate the extra maintenance.

I have pricing from two of the industry leaders in this technology and feel the upgrade will pay for itself in decreased service calls by our staff and contractors. The expenditure was budgeted for in Operating Supplies line item 590-540-752-000

I am requesting the approval by the council of the bid from JGM Valve of Commerce Mi. for two Vaughn Chopper Pumps for the cost of \$35,698.

Supplemental Information;

It was suggested by the City Administrator to advance additional information and add achieve the support of Otsego Township before our council approved the expenditure, as the cost mainly effect's their budget.

Enclosed is a copy of the letter to Otsego Township regarding bids for two new pumps at the 12th St. lift station. The ninety percent will be invoiced to the Township which will in turn be deposited into Sewer Fund Balance. The request was approved by their board on 9-12-2022 to purchase the Vaughn Chopper pumps.

Brad Keeler, Mayor
Lori Steele, Mayor Pro-Tem
Roger Kenney, Council Member
Todd Overhuel, Council Member
Randy Wisnaski, Council Member
www.plainwell.org



Bryan D. Pond, Superintendent
129 Fairlane Street
Plainwell, Michigan 49080
Phone: 269-685-5153
Fax: 269-685-1994
Email: BPond@plainwell.org

9/7/2022 (via e-mail)

Mr. Bryan Winn
Otsego Township Supervisor
400 N. 16th St. Otsego MI 49078

12th Street Pump Station

Mr. Winn

Thank you for you and your staffs time at the intermunicipal sewer meeting on September 1st 2022. As discussed, we are having continued plugging of the pumps which service the commercial district on M-89. The enclosed letter is to inform you and your board members and hopefully answer any question about the necessary purchase.

Since the beginning of the year we have invoiced the Township over \$4,000 for service calls related to the unplugging of the pumps at the 12th St lift station. This clogging of one of the two pumps also disrupts service for two to five days while the service company can schedule and attend to the station. This leaves the station with only one operating pump for this period which jeopardizes reliability and service to Otsego Township customers.

Accordingly, per the Sewer Use Agreement Otsego Township is responsible for ninety percent of all operational and maintenance costs as this percentage portrays the amount of sewage flow through the station each day. The City has had the pumps maintained to perform as best they can however with large cloth materials entering the sewer system another pump configuration needs to be explored.

Current pump technologies which handle this type of waste are “cutting-chopping” pumps. I have contacted two companies which are proven industry wide to remedy this type of operational problem.

We are proposing the Vaughn Chopper Pump because the sales and service representative is based in Michigan, and the parts are made in Washington State.

Cost Estimates;

Vaughn Chopper Pumps, parts and manufacturing in U.S.A., service Michigan
Pumps \$17,349 each, freight to be added. Install estimate \$2,500 freight est. \$1,000
Total \$38,198 90% of cost estimated at **\$34,378**

Landia Pumps parts and manufacturing Europe, service North Carolina
Pumps \$16,390 each, freight included. Install estimate \$2,500
Total \$35,280. 90% of cost estimated at **\$31,752**

Thank You

Bryan Pond
Superintendent of Water Renewal

Enclosure, pump quotes

cc: Erik Wilson, City of Plainwell, City Administrator
Jen Colin Otsego Township Clerk



1155 Welch Road – Suite D
 Commerce, Michigan 48390
 Phone: 248-926-6200 / Fax: 248-926-6290
 Attention: Bryan Pond
 Project: Plainwell MI – 12th Street PS

Quote Number: **Q48108A**
 08/23/2022
 Page 1 of 5

*DUE TO CONTINUED PRICING INSTABILITIES IN MOTORS, METALS AND CASTINGS
 ALL PRICING BEYOND 30 DAYS MUST BE VERIFIED PRIOR TO PLACING AN ORDER.*

ITEM	QTY	UNIT	DESCRIPTION	UNIT PRICE	TOTAL
------	-----	------	-------------	------------	-------

1	1	ea.	<p>Vaughan Model S4L-230/460-085 Submersible Chopper Pump consisting of: Casing, cast ductile iron with 4" ANSI CL 125 discharge flange. Impeller, Cutter Bar, Cutter Nut Upper Cutter, cast steel, heat treated to minimum Rockwell C60. Mechanical Seal, cartridge type with ductile iron gland, Viton O-rings, silicon carbide faces, and integral stainless-steel sleeve as manufactured by Vaughan. Elastomers, Buna N. Bearings, oil bath lubricated with minimum 100,000-hour L-10 bearing life. Bearing Housing, cast ductile iron with piloted motor mount. Bearing housing to be plugged unless item #2 (optional adder) is included. Shaft, heat treated steel Drive, 5 HP, 1150 RPM, 230V OR 460V, 3 phase, 60 Hz, 1.15 SF, Explosion Proof (Class 1, Group C & D) 15 minute in air continuous duty submersible motor with tandem mechanical seals, moisture sensors, internal thermostats, and (50) feet of power and control cable, manufactured by ABB/Baldor or EIM. Pump Finish: Solvent wash and coat with Tnemec Perma-Shield PL Series 431 epoxy. (Except Motor).</p>		
---	---	-----	------------------------------------------------------------------------------------------------------------------------------------------------------------------------------------------------------------------------------------------------------------------------------------------------------------------------------------------------------------------------------------------------------------------------------------------------------------------------------------------------------------------------------------------------------------------------------------------------------------------------------------------------------------------------------------------------------------------------------------------------------------------------------------------------------------------------------------------------------------------------------------------------------------------------------------------------------------------------------------------------------------------------------------------------------------------------------------------------------------------------------------------------------------------------------------------------------------------------------	--	--

TOTAL NET PRICE: \$17,349 \$17,349

Pump Performance: 300 GPM @ 27-FT TDH
Application: Pump Station
Industry: Municipal
Freight: not included / available upon request

Submittals: Production Time: FOB: Terms: Expiration:	Submittal time is 4 - 6 weeks after receipt of order. <u>Estimated 12 to 14 weeks after receipt of approved submittals, released to production and executed purchase order.</u> Estimated ship dates are subject to change dependent on motor availability. Vaughan Co. will arrange shipment upon the receipt of approved factory tests, if applicable. Montesano, Washington via best way. <u>PLUS FREIGHT</u> Contingent on credit approval. Quotation valid for 30 days.
----------------------------------------------------------------------	--------------------------------------------------------------------------------------------------------------------------------------------------------------------------------------------------------------------------------------------------------------------------------------------------------------------------------------------------------------------------------------------------------------------------------------------------------------------------------------------------------

JMV

"First and Only Chopper Pump – Worldwide"



1155 Welch Road – Suite D
 Commerce, Michigan 48390
 Phone: 248-926-6200 / Fax: 248-926-6290

Attention: Bryan Pond
 Project: Plainwell MI – 12th Street PS

Quote Number: Q48108A

08/23/2022

Page 2 of 5

*DUE TO CONTINUED PRICING INSTABILITIES IN MOTORS, METALS AND CASTINGS
 ALL PRICING BEYOND 30 DAYS MUST BE VERIFIED PRIOR TO PLACING AN ORDER.*

ITEM	QTY	UNIT	DESCRIPTION	UNIT PRICE	TOTAL
------	-----	------	-------------	------------	-------

NOTE:

THE FOLLOWING OPTIONAL ITEMS ARE NOT INCLUDED IN THIS QUOTATION. IF REQUIRED, PLEASE CONTACT YOUR LOCAL VAUGHAN REPRESENTATIVE FOR PRICING AND AVAILABILITY: UNLESS NOTED OTHERWISE, VAUGHAN'S STANDARD WARRANTY APPLIES.

- GAUGES, SWITCHES, VALVES AND OTHER SPECIALTIES NOT SPECIFICALLY CALLED OUT HEREIN.
- SPECIAL COATINGS OTHER THAN THOSE QUOTED.
- FACTORY PERFORMANCE, HYDRO, VIBRATION AND NOISE TESTS.
- EQUIPMENT, LABOR, MATERIAL AND PERSONNEL REQUIRED TO PERFORM FIELD TESTING OF PUMPS.
- ENGINEERING SUBMITTALS.
- SPECIAL MOTOR SPECIFICATIONS INCLUDING HIGH EFFICIENCY, MILL AND CHEM DUTY, INTERNAL SPACE HEATERS, ETC.
- FACTORY MOTOR TESTS.
- STARTUP BY MANUFACTURER'S REPRESENTATIVE.
- LEVEL CONTROLS OR CONTROL PANELS.
- SPARE PARTS.
- ADDITIONAL LUBRICANTS OTHER THAN THOSE CONTAINED WITHIN THE PUMP.
- ANCHOR BOLTS.
- ACCESS HATCH COVERS OR HOISTS.
- 2 INCH PIPE RAILS FOR GUIDERAILS.
- LIFTING CABLES AND SAFETY HOOKS.

Chuck Bugeja / cjb – JGM Valve Corporation.

Submittals: Submittal time is 4 - 6 weeks after receipt of order.
 Production Time: **Estimated 12 to 14 weeks after receipt of approved submittals, released to production and executed purchase order.** Estimated ship dates are subject to change dependent on motor availability. Vaughan Co. will arrange shipment upon the receipt of approved factory tests, if applicable.
 FOB: Montesano, Washington via best way. **PLUS FREIGHT**
 Terms: Contingent on credit approval.
 Expiration: Quotation valid for 30 days.

JMV

"First and Only Chopper Pump – Worldwide"



VAUGHAN CO., INC. PRODUCT WARRANTY

Vaughan Company, Inc. (Vaughan Co.) warrants to the original purchaser/end user (Purchaser) all pumps and pump parts manufactured by Vaughan Co. to be free from defects in workmanship or material for a period of one (1) year from date of startup or eighteen (18) months from the date of shipment from Vaughan Co., whichever occurs sooner. Startup data must be submitted to Vaughan Co. within 30 days of startup. If Purchaser fails to submit startup data within 30 days of startup, then Vaughan, in its sole discretion, may elect to void this warranty at any time. Purchaser must contact Vaughan Co. prior to commencing any repair attempts, or removing pump or parts from service. If Purchaser fails to contact Vaughan Co. prior to commencing any repair attempts or removing pumps or parts from service, then Vaughan, in its sole discretion, may elect to void this warranty at any time.

If during said warranty period, any pump or pump parts manufactured by Vaughan Co. prove to be defective in workmanship or material under normal use and service, and if such pump or pump parts are returned to Vaughan Co.'s factory at Montesano, WA, or to a Vaughan authorized Service Facility, as directed by Vaughan Co., transportation charges prepaid, and if the pump or pump parts are found to be defective in workmanship or material, they will be replaced or repaired by Vaughan Co. free of charge. Products repaired or replaced from the Vaughan Co. factory or a Vaughan authorized Service Facility under this warranty will be returned freight prepaid. Vaughan Co. shall not be responsible for the cost of pump or part removal and/or re-installation.

All warranty claims must be submitted in writing to Vaughan Co. not later than thirty (30) days after warranty breach occurrence. The original warranty length shall not be extended with respect to pumps or parts repaired or replaced by Vaughan Co. under this Warranty. This Warranty is voided as to pumps or parts repaired/replaced by other than Vaughan Co. or its duly authorized representatives.

Vaughan Co. shall not be liable for consequential damages of any kind, including, but not limited to, claims for property damage, personal injury, attorneys' fees, lost profits, loss of use, liability of Purchaser to customers, loss of goodwill, interest on money withheld by customers, damages related to third party claims, travel expenses, rented equipment, third party contractor's fees, or unauthorized repair service or parts. The Purchaser, by acceptance of delivery, assumes all liability for the consequences of the use or misuse of Vaughan Co. products by the Purchaser, its employees or others.

Equipment and accessories purchased by Vaughan Co. from outside sources which are incorporated into any Vaughan pump or any pump part are warranted only to the extent of and by the original manufacturer's warranty or guarantee, if any, which warranty, if appropriate, will be assigned by Vaughan Co. to the Purchaser. It is Purchaser's responsibility to consult the applicable product documentation for specific warranty information. Specific product documentation is available upon request. Any warranty shall be void if the total contract amount is not paid in full.

Vaughan Co. neither assumes, nor authorizes any person or company to assume for it, any other obligation in connection with the sale of its equipment with the exception of a valid Vaughan "Performance Guarantee" or "Extended Warranty," if applicable. Any other enlargement or modification of this warranty by a representative or other selling agent shall not be legally binding on Vaughan Co.

Warranty eligibility determination is at Vaughan Co.'s sole discretion.

Warranty Limitations:

This warranty shall not apply to any pump or pump part which has been subjected to or been damaged by any of the following non-exclusive list of causes:

- Misuse
- Abuse
- Accident
- Negligence
- Operated in the dashed portion of the published pump curves
- Used in a manner contrary to Vaughan's printed instructions
- Defective power supply
- Improper electrical protection
- Faulty installation, maintenance, or repair
- Wear caused by pumping abrasive or corrosive fluids or by cavitation
- Dissatisfaction due to buyer's remorse
- Damages incurred during transportation
- Damages incurred during installation or maintenance

THIS IS VAUGHAN CO.'S SOLE WARRANTY AND IS IN LIEU OF ALL OTHER WARRANTIES, EXPRESSED OR IMPLIED, WHICH ARE HEREBY EXCLUDED INCLUDING IN PARTICULAR ALL WARRANTIES OF MERCHANTABILITY OR FITNESS FOR A PARTICULAR PURPOSE.



ENGINEERED TO LAST

August 17, 2022

Project: Lift Station Chopper Pumps
Replace ABS Pumps

Contact: Bryan Pond
Company: City of Plainwell, MI
Address: 129 Fairlane Street
Plainwell, MI 49080
Email: BPond@plainwell.org

Reference: Landia Project No. 75586

Landia, Inc.

111 Triangle Trade Drive
Cary, North Carolina 27513
Phone: 919-466-0603
Fax: 919-460-1666
Email: info@landiainc.com
Website: www.landiainc.com

Dear Bryan:

Thank you for your interest in the Landia Chopper Pump and its application to replace ABS pumps in a Lift Station. Landia has selected the model DG-I 80 submersible chopper pump as its choice for the requirements of the application. Landia has manufactured chopper pumps for over 70 years, with thousands of installations globally. Landia's chopping system is separate from the pumping system, ensuring a non-plugging operation. With Landia's simple approach to chopping and pumping we are able to supply the answers to all your jobs.

Requirements for Submersible Chopper Pumps

	<u>One (1) Lift Station</u>
Tank Dimensions	10' diameter x 30' deep
Duty Point, per pump	300 gpm @ 27' TDH
Pumped Liquid	Raw wastewater; less than 1% solids.
Pump Application	Chop and pump the wastewater.



Quotation for Submersible Chopper Pumps

Two (2) Chopper Pumps, model DG-I 80 6.5 HP 1800, 3ph/240V/60Hz are equipped with the following:

- Cast Iron Motor and Pump Housing
- Explosion-Proof Motor
- Thermal Sensors in the Windings
- 40' Power Cable
- 40' Stainless Steel Chain
- Hardened Steel Knife System
- Stainless Steel Suspension/Lifting Bracket
- Polypropylene Cable Mesh
- Adapter for ABS Guide Claw

Principal drawing no. 37A0639

Price per two (2) units includes the above equipment \$32,780.00

Please note the following:

- The pumps are quoted for installation onto the existing guide rail systems and as such, this proposal does not include installation accessories or the discharge elbow. Adapters will be provided for bolting the existing guide claws onto the Landia chopper pumps. Additional information will be required prior to Landia manufacturing the custom flange adapters.
- Owner is responsible for verifying the existing guide rail system and guide claw are in suitable condition to support the Landia chopper pump.
- As an alternative to using the existing system, Landia can provide new installation components (cast iron guide claw and discharge elbow, and stainless steel guide pipe assembly). This option would be available for an adder of \$2,600 to the above quoted price.
- The pumps must be completely submerged while operating.

Crane Arm Assembly

One (1) Hot Dip Galvanized Portable Crane assembly includes the following:

- Rotatable Horizontal Telescopic Crane Arm
- Winch with Lifting Wire
- Stainless Steel Hook
- Intermediate Piece
- Relief Chain
- Cover for Winch
- Base for Crane Arm

Price per one (1) unit includes the above equipment \$3,650.00

Please note: The crane arm assembly is portable and may be used on multiple pumps.

Startup and training services (one trip / one day) \$1,500.00

Total price \$37,930.00

Items not Included

- VFD / Control Panel
- Installation
- Field Wiring
- Field Testing
- Anchor Bolts
- Any other device, equipment, materials, or labor not specifically called out in this proposal.
- Seal Control
- Spares
- Discharge Elbow
- Guide Pipe Assembly

Additional Information

- **Our prices include duties and freight to City of Plainwell, MI.**
- We do not collect and are not responsible for any sales and use taxes. If these taxes are applicable, you are responsible for remitting them directly to your state's Department of Revenue.
- Prices valid for 60 days from proposal date.
- Payment conditions will be defined at the time of the order.
- Delivery: 10-12 weeks after drawing approval, if required. Allow 3-5 weeks for submittals after receipt of purchase order.
- We are pleased to attach the following documents:
 - Principal Drawing no. 37A0845
 - Technical Data Sheet
 - Pump Performance Curve
 - General Terms of Sales and Delivery

Pump recommendation is based on the information available to Landia as of the date of this proposal. We reserve the right to make any necessary alterations to the information stated above when this offer becomes a firm order.

We trust our proposal is of interest and look forward to hearing from you.

Sincerely,



Soren B. Rasmussen
Sales Director

SBR/QCM/jam

COPYRIGHT - This drawing is the property of Landia and cannot be shown, copied, given to a third party or used in any other way without permission from Landia.

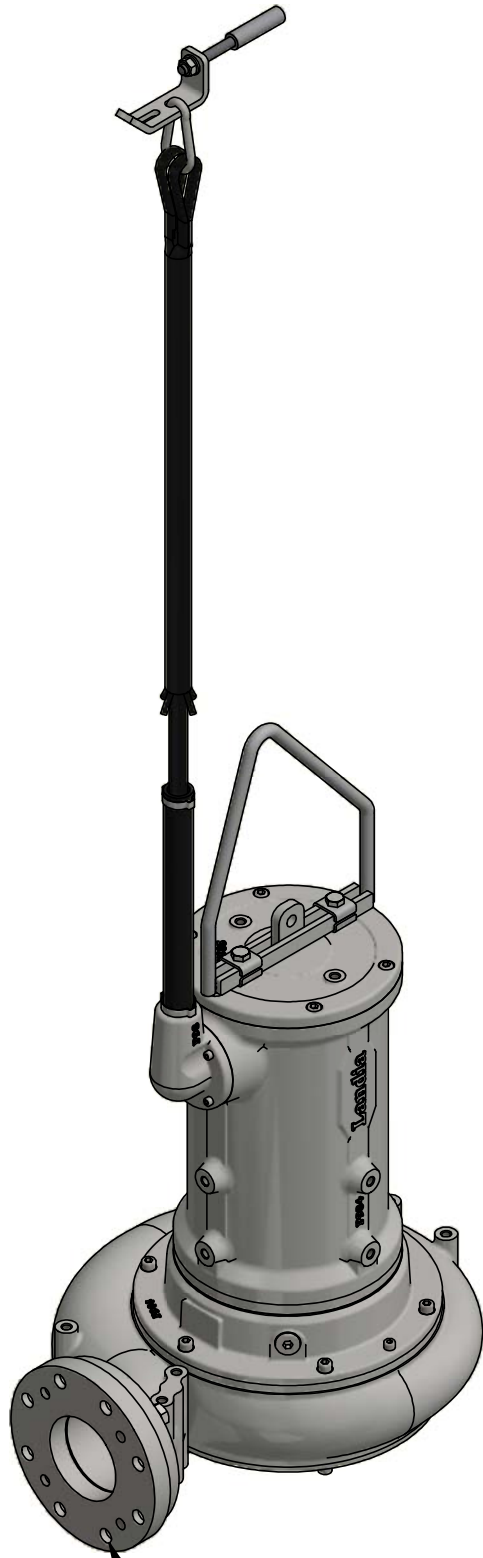

Threaded bolt holes
for coupling clutch installation

Landia

DG-I
With suspension bracket
and adapter flange

Scale:	Sign.:	Date:
1 : 8	VFO KSK	31-08-2021
Dwg.no.:	37A0845	

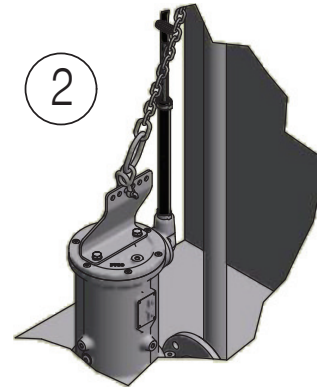
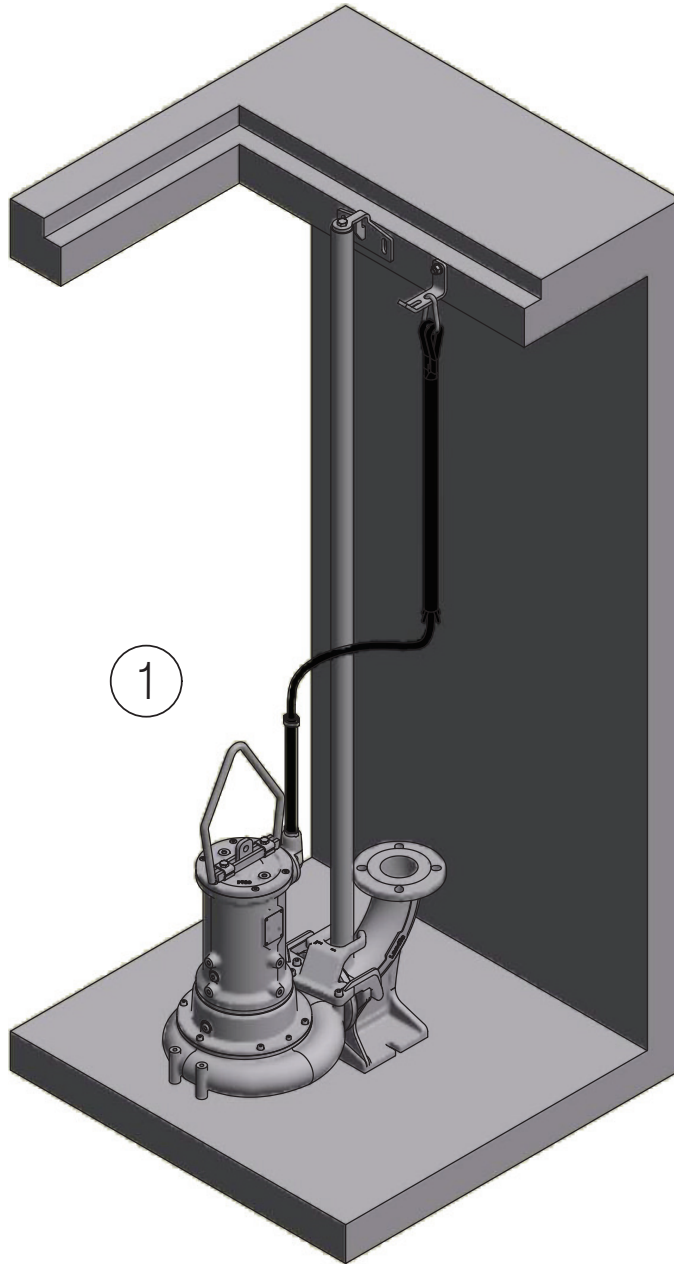

1:10

A

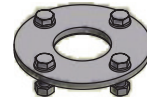

B

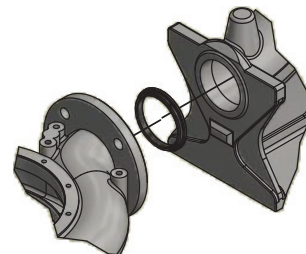
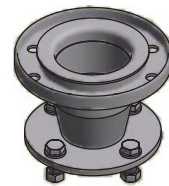

COPYRIGHT - This drawing is the property of Landia and cannot be shown, copied, given to a third party or used in any other way without permission from Landia.

Landia

DG-I 65-105
w/coupling system
Principal drawing

Scale:	Sign.:	Date:
1 : 15	HL KSK	03-08-2017
Dwg.no.:		37A0639
Revision date: 07-12-2020		

Article no. 2324814 Submersible Pump Model DG-I 80 6.5 HP, medium pressure

Manufacturer.....	LANDIA	
Type.....	DG-I	
Impeller revolutions.....	1735 rpm	
Motor series.....	100	
Weight.....	187 lb.	
Electrical cable.....	7 × AWG 14	
Controls.....	Thermal sensors 120°C	
<i>Option</i>	<i>Seal control</i>	<input type="checkbox"/>
Exterior and interior seals.....	Mechanical shaft seals	

Pressure Side:

Discharge diameter.....	Ø 80 mm
Dividing circle/bolt holes.....	Ø 150 mm/4 pcs Ø18 (DIN 2631)

Material:

Motor housing and oil chamber.....	Cast iron AISI A48-40B	
Pump housing.....	Cast iron AISI A48-40B	
Impeller.....	Cast iron AISI A48-40B	
Bolts and screws.....	Stainless steel AISI 316	
Mechanical shaft seals.....	Silicon carbide/Silicon carbide	
Surface coating.....	Painted	
<i>Option</i>	<i>2-component coating</i>	<input type="checkbox"/>
Knife system: 1 fixed and 2 rotating knives.....	A570 Gr 36 hardened	
<i>Option: 3 fixed and 2 rotating knives.....</i>	<i>Extended knife system</i>	<input type="checkbox"/>

Motor:

Manufacturer.....	LANDIA	
Type.....	DM 6.5.4	
Rated effect.....	6.5 HP	
Revolutions.....	1735 rpm	
Phases × voltage, frequency.....	3 × 230 V, 60 Hz	
Start current direct.....	132.5 A	
Rated operating current.....	18.1 A	
Power factor, cos φ.....	0.78	
Cage class.....	IP 68	
<i>Option</i>	<i>Class I, group C & D</i>	<input checked="" type="checkbox"/>
Insulation class.....	F	
Minimum voltage allowed.....	210 V	

Oil:

Type, standard.....	Castrol Tecton 15W40
<i>Type, for seal control.....</i>	<i>Castrol Hyspin HVI 46D</i>
Quantity.....	2.7 quarts
Recommended service interval/oil change.....	every 2,000 hours of operation or minimum once a year



Pump model 80, impeller type 3

6.5 HP, 1800 rpm, 60 Hz

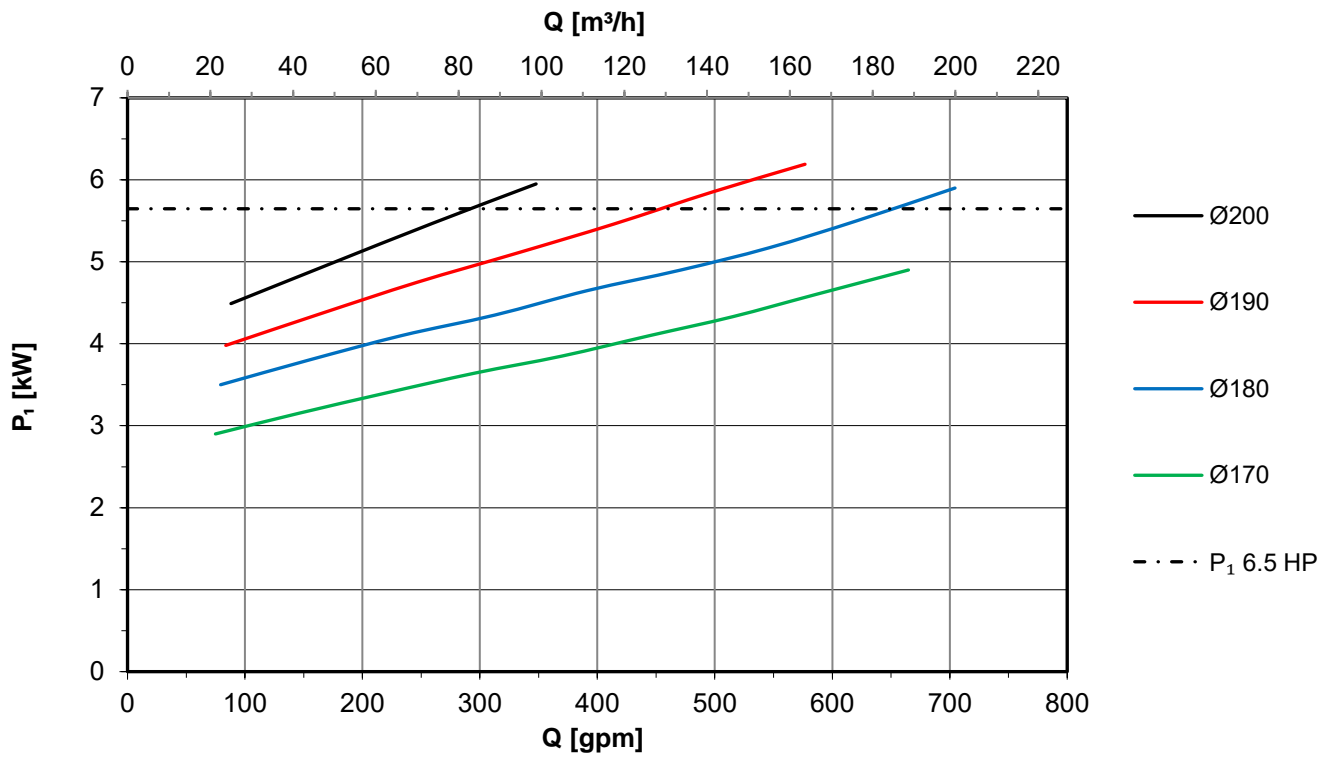
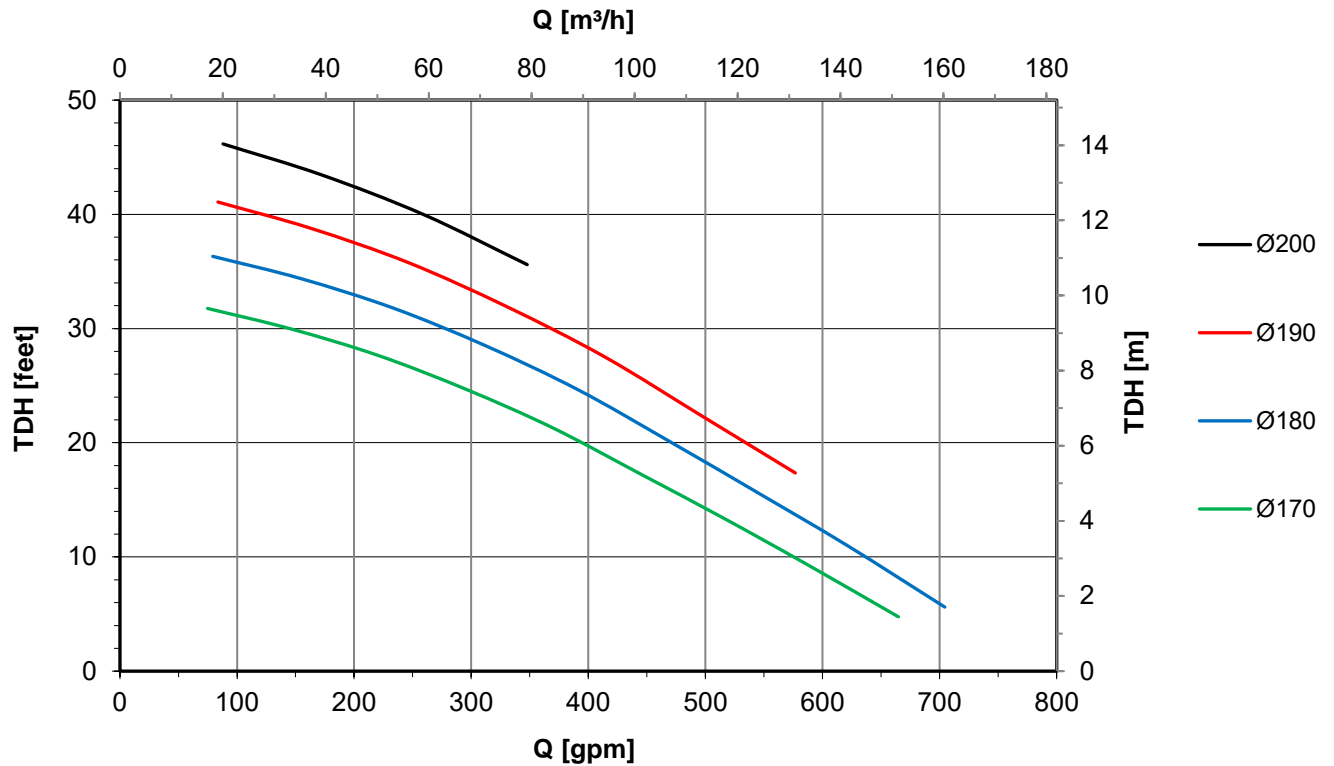

Clean water 20 °C

Conditions of Sale

Page 1/2

A. **Acceptance**

This quotation is void at our option unless a purchase order is placed with us within sixty (60) days from date of bid opening or date of written proposal. The order will be subject to written acceptance by our company's executive office. In the absence of this, the Buyer's written order will be valid. Our quotation is limited to only those technical portions of the Engineer's Mechanical Specifications specifically referred to herein, and to the terms and conditions of sale as outlined in our quotation. We will not be bound by any Terms and Conditions of the prime Contract not specifically included herein.

B. **Terms**

Net due thirty (30) days after the date of invoice unless otherwise stated in the proposal. These terms are subject to approval by our Credit Department. Your payment to us will not be dependent or contingent upon receipt of payment by you or any other parties. Any balance remaining due thirty-one (31) days beyond the due date will be subject to a monthly service fee until paid. Should we have to engage an attorney to collect the balance due us, including the service fee, you agree to reimburse us for all collection costs including reasonable attorney fees. The Buyer is responsible for all bank charges and fees in connection with payment. Payment by cheque is not approved until the cheque has been cashed by the Buyer's bank.

C. **Taxes & Other Charges**

Unless otherwise indicated, no Sales, Use, Retailer's Occupation, Service Occupation, Service Use, or similar taxes and similar charges, have been included in our prices. The amount of any such taxes or charges which are paid or assessed in connection with this order and which are not specifically stated as being included in the purchase price, shall be paid by you, either directly to the appropriate authorities (in which event you shall furnish us with satisfactory evidence of such payments) or to us if we have paid, or are required to pay, such taxes or charges. If you are tax exempt on this job, you will need to supply us with your exemption certificate. You agree to reimburse our company for taxes we must pay on your behalf. You are responsible for obtaining permits in connection with the sale or installation of our equipment.

D. **Warranty**

Landia Inc. warrants to Buyer that equipment sold hereunder, of its manufacture, is free from defect in material and workmanship, and is of the kind and quality designated or described herein. This warranty shall run to Buyer and, if applicable, such entity specifically identified in the Primary Contract only, but not to their employees, representatives, agents, customers, assignees, etc., and applies to those technical portions of the Engineer's Specifications only to the extent that they are referred to herein. This warranty shall be in full force and effect at the time of shipment of such equipment for a period of one (1) year from the date of invoice. Landia Inc. undertakes and reserves the right to free of charge to redress at their works or to exchange defect products. The parts replaced transfer automatically to the manufacturer's property and must be returned to them as agreed. Expenses or costs incurred with the return and re-assembly or corresponding arrangements and indirect loss and damage will not be compensated. The obligation of Landia Inc. to replace or redress such defective parts shall be the exclusive remedy hereunder. Buyer must give Landia Inc. notice in writing of any other alleged defect covered by this warranty within thirty (30) days of the discovery of such defect during the warranty period. No claim more than thirty (30) days after the warranty period shall be valid. The warranty extends to replaced parts of Landia Inc.'s manufacture for ninety (90) days or the remainder of the original warranty period applicable to the parts being replaced.

This warranty shall not apply to:

- A. Any equipment which has been subjected to misuse, neglect, or accident;
- B. Any equipment which has been altered, tampered with, or upon which corrective work has been done thereon without Landia Inc.'s specific written consent;

- C. Any equipment which has been operated or maintained in a manner which in any way deviates from the maintenance schedules, specifications, and parameters set forth in Landia Inc.'s Operator's Manual for such equipment.

No allowances will be made for any such alterations or corrective work done without the specific written consent of Landia Inc. Conditions caused by improper lubrication, deterioration by chemical action, and wear caused by the presence of abrasive materials, do not constitute defects. Equipment manufactured by others, and included in Landia Inc.'s proposal, is not warranted in any way by Landia Inc. but carries only that manufacturer's warranty, if any.

No representative of Landia Inc. has any authority to waive, alter, vary, or add to the items hereof without prior written approval.

THE FOREGOING WARRANTY IS EXCLUSIVE AND IN LIEU OF ALL OTHER GUARANTEES AND WARRANTIES OF QUALITY, WRITTEN, ORAL OR IMPLIED; ALL OTHER WARRANTIES, INCLUDING ANY WARRANTY OF MERCHANTABILITY OR FITNESS FOR PURPOSE ARE HEREBY EXPRESSLY DISCLAIMED.

E. **Security Interest**

Until all amounts due hereunder have been paid in full, Seller has a security interest in the equipment and has all rights of a secured party under the Uniform Commercial Code including, without limitation, the right to take possession of the equipment without legal process and the right to require Buyer to assemble the equipment and make it available to Seller at a place reasonably convenient to both parties. At Seller's request, Buyer shall execute any financing statement or statements submitted by Seller in order that Seller's security interest in the equipment may be perfected.

F. **Changes & Delays-Cost**

If you cause changes to be made, or delay or interrupt the progress of the work, you will reimburse us for any additional expense resulting from such cause. Any of such changes or delays which may adversely affect the operation of the equipment will nullify our warranty unless we consent in writing thereto.

G. **Delays**

We shall not be liable for delay in delivery caused by any reason beyond our control, including but not limited to your delay in promptly submitting all information necessary for us to proceed with the work, your delay in approval of drawings, acts of God, casualty, civil disturbance, labor disputes, strikes, transportation, supply difficulties, any interruption of our facilities, or any of the governmental authorities. In the event of such conditions, Landia Inc. is entitled to cancel the order or to extend the time for delivery specified herein during the continuance of such conditions and for a reasonable time thereafter.

H. **Claims**

Claims for errors or shortages existing prior to our delivery of the equipment to the carrier will be considered only when made to us immediately after receipt of shipment. Claims shall be confirmed in writing. Buyer shall immediately inspect the equipment upon receipt thereof. Seller is not obligated to consider any claim for shortages or non-conformance unless notified thereof by Buyer within eight (8) days after Buyer's receipt of equipment. Modifications to the equipment furnished by Landia Inc. to meet OSHA or local safety codes will be by others. Seller will supply only the safety devices, if any, described in the order. LANDIA INC. assumes no responsibility for any costs, direct or indirect, resulting from disapproval of our tender by the owner.

I. **Transportation Expense**

Unless otherwise noted, the prices shown in this proposal include freight to the destination shown, at lowest available freight rates on a common carrier of our choice. If you require us to ship another way, you will bear any additional expense. Landia Inc. will provide and maintain in responsible insurance companies, at its own expense, insurance against loss and damage to the equipment by fire or other casualty during transportation of the equipment from Landia Inc.'s works and to the final destination of the equipment. In order for our company to insure delivery, it is agreed by you and our company that you will provide us with an access road to and from the job site, which road is capable of supporting trucks. The responsibility for the protection of equipment will be yours after it is delivered to the job site. Damage to the equipment after delivery which is caused by vandalism, the elements or otherwise, will be your responsibility and not that of our company.

Conditions of Sale

Page 2/2

J. Liability

It is expressly understood that our liability, including that for negligence, for our products is limited to the furnishing of such replacement parts, and that we will not be liable for any other expense, injury, loss or damage, whether direct or consequential, including but not limited to loss of profits, production, increased cost of operation, or spoilage of material, arising in connection with the resale or use of, or inability to use, our equipment or products for any purpose except as herein provided.

K. Liquidated Damages

If awarded this contract, we will diligently prosecute the engineering and fabrication of the proposed equipment; however, we are unable to accept any liquidated damages or penalty clauses for failure to complete shipment as designated in this proposal.

L. Installation Representative

At your request, and subject to our option and availability of personnel at time of requirement, we will provide the services of a competent person to advise you concerning the installation of the equipment covered by this proposal. These services are not supervisory but are advisory only, and are offered subject to the express understanding that our function and responsibility is limited to interpretation of assembly drawings and identification of materials for their proper location in the equipment or system layout. These services are offered on a "no risk" basis by Landia Inc.

In payment for such services, you will reimburse us at the current rate for each normal working day, or fraction thereof, that such person is absent from our plant on your business. The normal working day shall be eight (8) hours, between 8:00 AM and 4:30 PM, Monday through Friday, exclusive of holidays. All service performed by our representative at your request in addition to a normal working day, as herein defined, shall be classified as overtime work. If circumstances dictate that our representative shall work exclusively during hours other than those of the normal working day, arrangements can be made. The day rate is subject to change to the rate in effect at the time representative is furnished. You will also reimburse us for all transportation and living expenses incurred by our representative while absent from our plant on your business.

M. Cancellation

Cancellation or suspension of a contract will be accepted only upon terms that will indemnify Landia Inc. against loss. You agree to reimburse our company for our costs incurred in such cancellation, including overhead and administrative costs. Our company may cancel the order prior to or at the time of receiving the final approved drawings if our company deems itself insecure, or determines that it is commercially unreasonable for us to proceed. In this event, you will be refunded any and all deposits you have made to us.

N. Contract

We both agree that this contract contains the complete and final agreement between us and may not be modified, supplemented, explained, or waived by oral evidence, your purchase order, course of dealing, or in any other way, except where made in writing and signed by you and our company's authorized officer.

O. Arbitration

Any controversy or claim arising out of or relating to this transaction shall be settled in Cary NC by arbitration in accordance with the Rules of the American Arbitration Association, and judgement upon the award rendered by the Arbitrator may be entered in any court having jurisdiction hereof.

P. Confidential Information

All information and data herein furnished to Buyer hereunder, relating to price, size, type and design is submitted with the understanding that it is for the Buyer's own confidential use and is not to be shown or otherwise made known or available to any third party at any time without Seller's written consent.

Q. Validity

Should an individual section of these conditions – regardless of reason – be invalid, this will not affect the validity of the remainder.



"The Island City"

MEMORANDUM

211 N. Main Street
Plainwell, Michigan 49080
Phone: 269-685-6821
Fax: 269-685-7282

TO: City Council
FROM: Robert Nieuwenhuis Public Works Superintendent
DATE: September 22, 2022
SUBJECT: Large tree removal

ACTION RECOMMENDED: The City Council should consider approving Blankenship Logging for removal of City trees.

Bids Received: Blankenship Logging- \$16,600
Fitzpatrick- Looked at trees never turned bid in.
Dan's tree service- Looked at trees and couldn't get a crane.

Bid Recommended: Blankenship Logging

Total Cost: \$16,600

Vendor Source:

Budget Impact: Local and Major Streets

Background Information: This would be the first job Blankenship would be performing for the City of Plainwell. They came highly recommended and have provided their services to City residents. These trees are very large dangerous trees that will need a crane for removal, this is why it has been a challenge to get quotes. I recommend we approve Blankenship Logging to perform the tree removal.

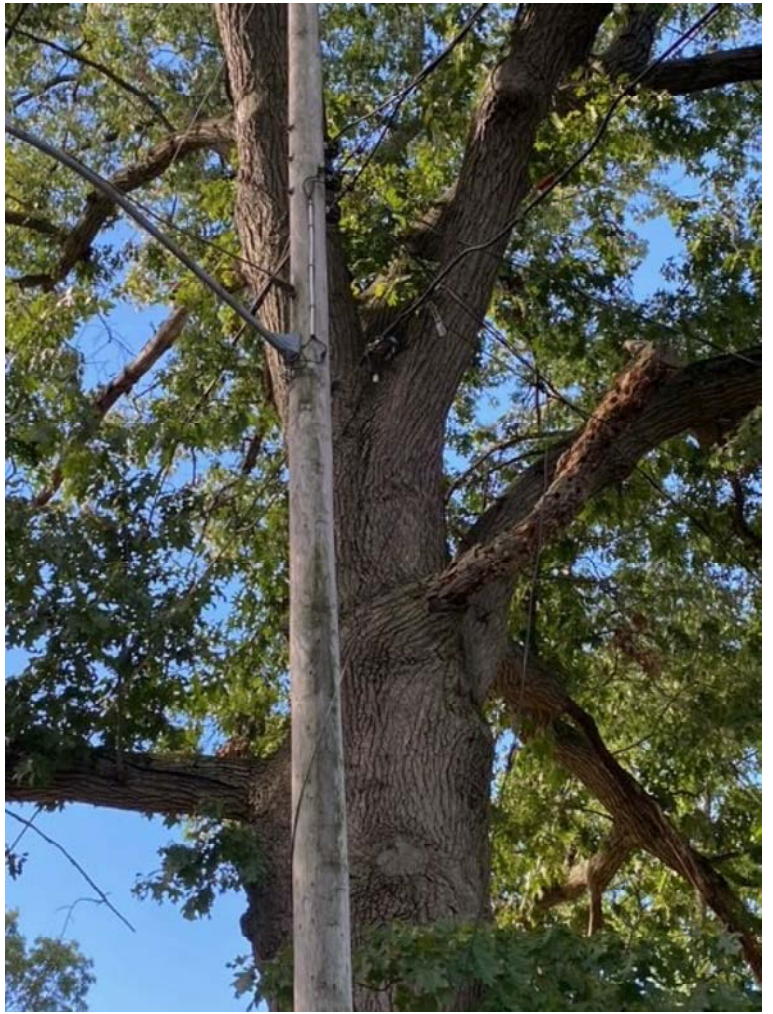

Resolution 2022-17
City of Plainwell Approved Financial Institutions as Depositories

WHEREAS, the City of Plainwell, in exercising its fiduciary responsibilities, desires to safeguard the funds of the City that may be invested from time to time; and

WHEREAS, the Charter of the City of Plainwell, Section 7.8, requires that the City Council designate the bank or depositories for the money belonging to the city; and

WHEREAS, Resolution 2010-01 was passed on September 27, 2010 authorizing the City Treasurer to manage funds belonging to the city, including depositing funds in approved financial institutions and administration of investments in conformance with city policy;

NOW, THEREFORE BE IT RESOLVED, that the City Council of the City of Plainwell approved the following financial institutions as depositories of city funds:

United Bank of Michigan, Grand Rapids, MI
Horizon Bank, Michigan City, IN
Grand River Bank, Grandville, MI
First National Bank of America, Grand Rapids, MI
Huntington Bank, Columbus, OH
Northstar Bank, Bad Axe, MI
Flagstar Bank, Troy, MI
Mercantile Bank of Michigan, Grand Rapids, MI
Consumers Credit Union, Oshtemo, MI
Arbor Financial Credit Union, Oshtemo, MI

AND BE IT FURTHER RESOLVED, that the City Council of the City of Plainwell designates the City Manager, the City Treasurer and the Personnel Manager/Coordinator as signors on all accounts.

YES:

NO:

ABSENT:

DATED: September 26, 2022

Bradley Keeler, Mayor

I hereby certify that the foregoing is a true and complete copy of a Resolution adopted by the City Council of the City of Plainwell at a regular meeting held on the date first stated above, and I further certify that public notice of such meeting was provided by law.

Margaret Fenger, City Clerk

Water Renewal

Superintendent: Bryan Pond

August 2022



Significant Department Actions and Results

The DYSTOR PLC computer system was changed out as part of last years budget process one part was backordered for several months. The PLC was changed due to obsolesence of parts.

We had a meeting with a company wanting to connect to one of our customer communities line,several weeks have gone by with none of the data we need to analyze to see is the project is feasible.

The 12th St lift station pump plugging continues I have recieved two prices on pumps which would eleviate the problem. I will present the information next month to Otsego Township at the intermunicipal sewer meeting.

Pending Items (including CIP) FY 21/22

Replace DYSTOR methane gas holding membrane

Replace 12th St lift station to "Chopper" style pumps

Clean (2) Digesters

Expenditure Summary/Issues

(budgeted)

(completed)

\$318,000

10% payment to order

\$38,000

90% of project payed by O.T.

\$20,000

Monthly Flow Data

Our permitted volume of treatment is 1,300,000 gallons per day. The table and graph below shows the breakdown of average monthly flow from our customer communities, the percent ownership of our customer communities.

	Total Gallons	Permitted Daily Flow Gallons	Reserve	Ownership of Plant Capacity
Village of Martin	957,223			
Gun River MH Park	493,000			
US 131 Motor Sports Park	98,000			
Total:	1,548,223			
AVG. DAILY:	43,006	180,000	76%	14%
Otsego Township	Total: 4,286,750			
	AVG. DAILY: 119,076	250,000	52%	19%
Gun Plain Township	Total: 1,388,000			
North Point Church	1,000			
North 10th Street	521,545			
Gores Addition	307,000			
AVG. DAILY	61,598	150,000	59%	12%
City of Plainwell	Total: 4519584			
	AVG. DAILY: 145793.02	720,000	80%	55%
Avg. Daily Plant Flow from entire service district	0.38			

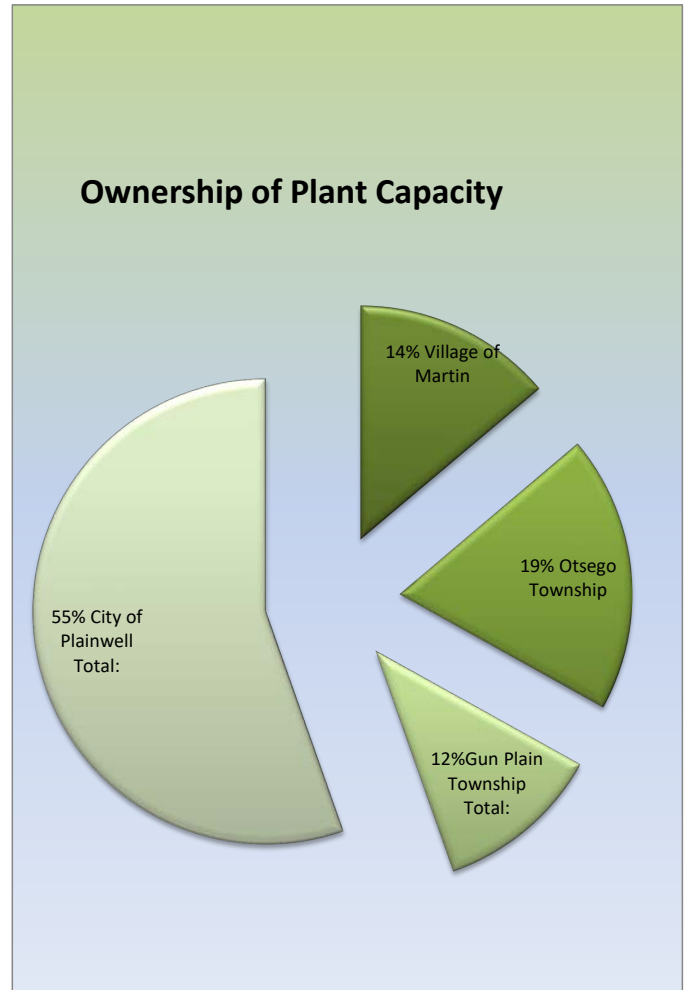
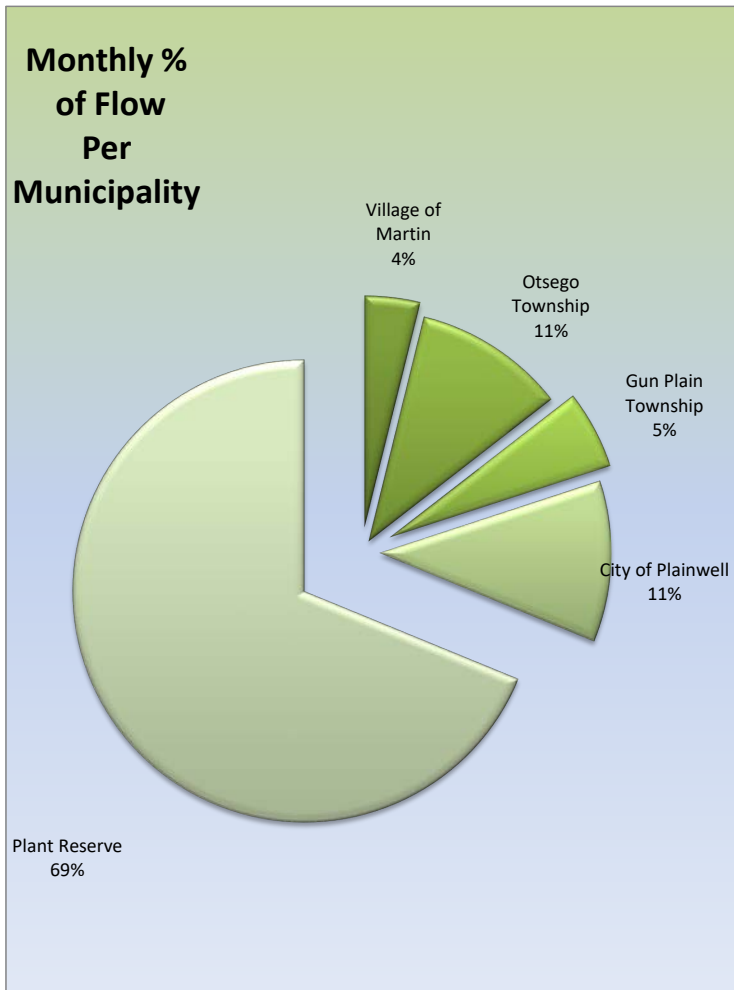

State Required Reporting Compatible Pollutants

MI State Requirement	City Benchmark	Monthly Avg. Reported/MDEQ
----------------------	----------------	----------------------------

Carbonaceous Biochemical oxygen demand (CBOD-5):

25 mg/l	15	8.32
---------	----	------

This test measures the amount of oxygen consumed by bacteria during the decomposition of organic materials. Organic materials from wastewater treatment facility act as a food source for bacteria.

TOTAL SUSPENDED SOLIDS (TSS):

30 mg/l	15	10
---------	----	----

Includes all particles suspended in water which will not pass through a filter. As levels of TSS increase, a water body begins to lose its ability to support a diversity of aquatic life.

PHOSPHORUS (P):

1.0 mg/l	0.45	0.70
----------	------	------

Controlling phosphorous discharges is a key factor in preventing eutrophication of surface waters. Eutrophication is caused by water enrichment of inorganic plant nutrients. Eutrophication negatively effects water bodies due to increases in algal blooming, causing excessive plant growth which depletes dissolved oxygen in the river which is necessary for aquatic life to survive.

Total Coliform (COLI):

200counts/ml	50	11
--------------	----	----

A group of bacteria found in soil, on vegetation and in large numbers in the intestine of warm-blooded animals, including humans. Water is not a natural medium for coliform organisms and their presence in water is indicative of some type of contamination.

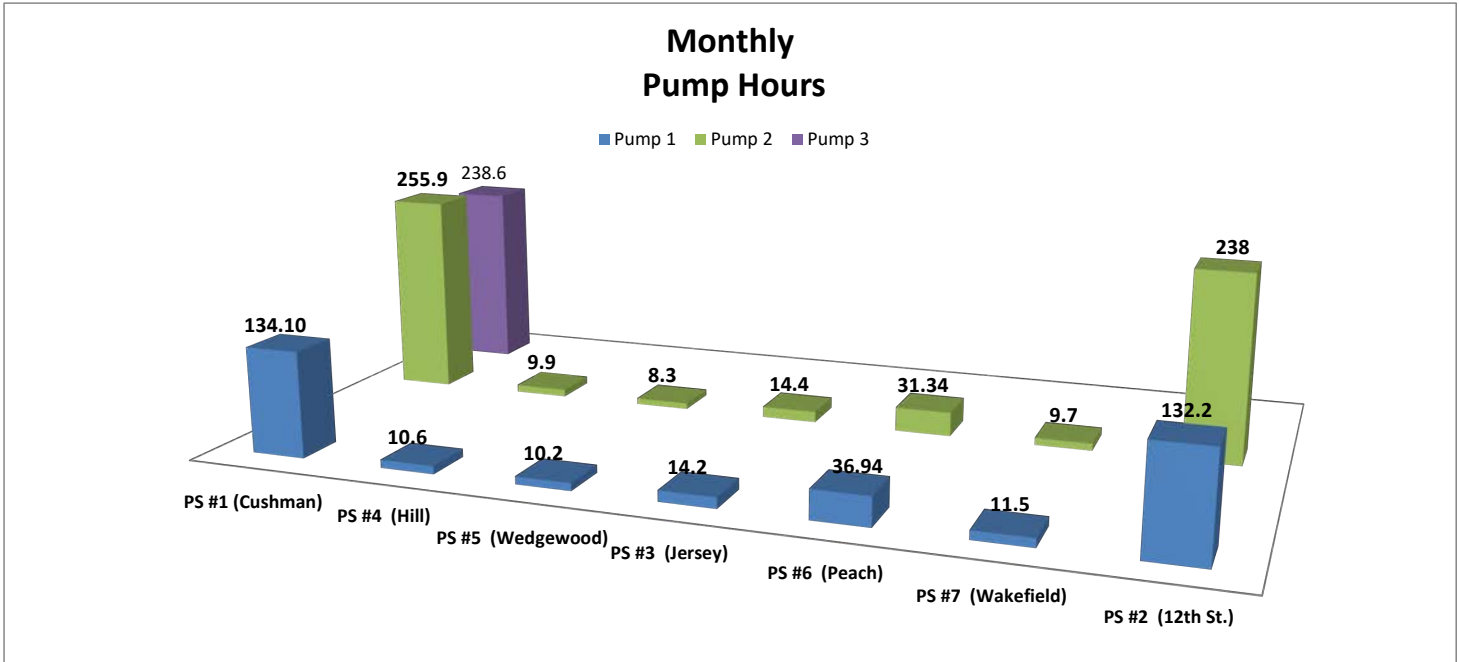

Pumps convey the waste where gravity sewers cannot, run times are a indicator of how the station is operating and being maintained.

Minutes
Plainwell DDA, BRA and TIFA:
September 13, 2022

1. Call to Order - Meeting called to order at 7:31 a.m. by Larabel
2. Pledge of Allegiance
3. Roll Call
Members Present: Randy Wisnaski, EJ Hart, David O’Bryant, Nick Larabel, Paul Rizzo, Adam Hopkins, Erik Wilson, Angela Ridgway
Excused: Jim Turley
Approval of Minutes of 08/09/22: Minutes were approved to place on file.
4. Chairman’s Report: None
5. BRA Action Items
 - A. Mill update by Wilson, City Manager – EGLE granted an extension on remaining funds; Holding back liquidated damages from Melching for items not completed on punch list. Building #2 brick issues.
 - B. Motion to accept accounts payable for August of \$24,069.05 was made by Rizo and seconded by Wisnaski. All in favor vote. Motion carried.**
6. DDA Action Items
 - A. Sign Ordinance revisions presented; O’Bryant left the meeting. **A motion to accept the revisions for the Sign Ordinance was made by Ridgway and seconded by Hart. All in favor vote. Motion Carried**
 - B. **Sound System/Holiday Decorations – A motion was made by Hart and seconded by Larabel to present BC Sound quote to City Council for sound system in Hicks Park. All in favor vote. Motion carried.**
 - C. Announcement regarding the Match on Main Street funds would be available to our community on October 3, 2022.
 - D. **Motion to accept accounts payable for August of \$549.66 was made by Larabel and seconded by Wilson. All in favor vote. Motion carried.**
 - E. **Special Guest: Director of Public Safety, Kevin Callahan**
7. TIFA Action Items
 - A. Update of Industrial Park Property – nothing new to report
 - B. Motion to accept accounts payable for August of \$786.53 was made Wisnaski and seconded by Hopkins. All in favor vote. Motion carried.**
9. Communications: 07/25/22 and 08/08/2022 Council Minutes. Also, the Financial Report/ Summary as of 8/30/2022 were approved and placed on file.
10. Public Comments: None
11. Staff Comments: Community Development Manager, Siegel reported:
Events: Farmers’ Market – prepping for Indoors
Businesses: Bridge St. Deli is selling; Highland Ridge Closing
Erik Wilson, City Manager reported:

Business/ Property - city now has key to Clark Gas Station; discussion with Ridderman to pump out tanks; Owner is trying to sell the property; Moving forward on enforcement. William Crispe updates building is back in City possession.

12. Member Comments: - None

13. Adjournment: **A Motion to adjourn the meeting at 8:56 a.m. was made by Rizzo and seconded by Hart.**

Submitted by Denise Siegel, Community Development Manager

DRAFT

**MINUTES
CITY OF PLAINWELL
PARKS & TREES COMMISSION
September 15, 2022**

1. Bunny LaDuke called the meeting to order at 5:02 PM.
2. Roll Call: Present: Marsha Keeler, Bunny LaDuke, Shirley DeYoung, Cory Redder, Todd Overhuel and Public Works Superintendent Bob Nieuwenhuis. Absent: Matthew Bradley.
3. Approval of Minutes:

Shirley DeYoung moved to accept and place on file the minutes of, August 11, 2022. Bob Nieuwenhuis supported the motion. On voice vote, motion carried unanimously.

4. Parks:
Bob reported that we fixed the hole in the River Walk yesterday. We have been paving so we out sourced our mowing in Kenyon Park. We will get back to mowing and taking the flowers down now that we are done with the paving.

Sherwood Park Maintenance Report – Shirley DeYoung

Shirley reported that she went by today and the park looks great. There were a lot of people using the park. Bob mentioned that someone had suggested to him that we should create a basketball court for little kids.

Pell Park Maintenance Report – Marsha Keeler

Marsha reported that the park looks good and there was nothing new to report.

Hicks Park Maintenance Report – Matthew Bradley

Matthew was unable to attend the meeting. Shirley had went to all the parks so she reported that everything looks good. Cory mentioned that people were letting their dogs poop on the boardwalk so maybe we should put a doggy bag dispenser near there.

Cook Park Maintenance Report – Cory Redder

Cory reported that park looked good and there were lots of people using the park. Especially using the pickle ball courts. The dog park was very busy too. Bob noted that we had just put more fresh woodchips in the park today. The area by the railroad tracks needs attention as there is a lot of garbage built up there.

Kenyon Park Maintenance Report – Bob Nieuwenhuis & Todd Overhuel

Todd reported that he drove by there today and it looks the same. Cory mentioned that his wife noticed a lot of garbage around the park so maybe we could say something to the Rocket football group to start cleaning up after themselves.

Darrow Park Maintenance Report – Bunny LaDuke

Bunny reported that there was nothing to report. Cory said that he noticed a kid fishing and he said he had caught some fish.

Riverwalk, Band Shell & CBD Maintenance Report – Cory Redder

Cory reported that there is still bees on the trestle. He also noticed that on the west side of the trestle there is part of the railing missing. He said the Band Shell looked good and there were a lot of people out for the karaoke event over Labor Day.

5. New Business
A. None.

B.

6. Open Business

A. The Five Year Recreation Plan had already been discussed in the meeting just before our Parks & Trees meeting.

7. Public Comments

None.

8. Staff Comments

None.

9. Chairman's Report

None.

10. Commissioners' Comments

Bunny mentioned that there was a nice article about the butterflies in the Union Enterprise. Todd said there was good responses from what Denise put on line too. There was light discussion on complaints about the Trestle Bridge. Todd Overhuel mentioned that the jail restoration fund had a little over \$300.00 in it.

11. Items For Next Agenda

12. Next Meeting

The next meeting will be Thursday, October 13, 2022 at 5 PM. Also we will have another Recreation Board meeting before our Parks & Trees meeting just before the meeting.

13. Adjournment

Marsha Keeler moved to adjourn the meeting. Shirley DeYoung supported the motion. On voice vote, motion carried unanimously.

There being no further business, the meeting adjourned at 5:29 PM.

Minutes Respectfully Submitted,
Cheryl Pickett

09/22/2022

INVOICE APPROVAL BY INVOICE REPORT FOR CITY OF PLAINWELL
INVOICE ENTRY DATES 09/09/2022 - 09/22/2022
BOTH JOURNALIZED AND UNJOURNALIZED
BOTH OPEN AND PAID

Vendor Code	Vendor Name	Description	Amount
000002	AT&T		
	269685195709	AIRPORT PHONE SERVICE 9.13 - 10.12.2022	60.79
	269685682409	DPS - LAND LINE SERVICE 9.13 - 10.12.2022	60.79
TOTAL FOR: AT&T			<u>121.58</u>
000004	PLAINWELL AUTO SUPPLY INC		
	669805	DPW - SKID STEER FITTING JF	13.29
	670074	DPW - SKID STEER HOSES/FITTINGS JF	114.90
	670262	DPW - SPANNER WRENCH FOR #152	125.65
	670822	DPW - COUPLING FOR TRUCK #12	15.59
TOTAL FOR: PLAINWELL AUTO SUPPLY INC			<u>269.43</u>
000009	CONSUMERS ENERGY		
	206257897920	ELECTRIC SERVICE - STREET LIGHTS JULY - AUGUST 2022	4,323.78
TOTAL FOR: CONSUMERS ENERGY			<u>4,323.78</u>
000014	MICHIGAN GAS UTILITIES CORP		
	4283732926	WR - GAS SERVICE 12TH ST 08/09 - 09/09/2022	42.04
	4285476932	ADMIN - GAS SERVICE 8/12-9/12/2022	39.39
	4285637412	DPS - GAS SERVICE 119 ISLAND 08/11 - 09/12/2022	40.38
	4286103042	CRISPE - GAS SERVICE 08/11-09/12/2022	85.27
	4286562412	DPW - GAS SERVICE 08/10-09/11/2022	85.85
	4287072938	WR - GAS SERVICE CUSHMAN 08/11-9/12/2022	45.97
	4287079973	WR - GAS SERVICE 08/11-09/12/2022	1,525.91
	4287395512	DPW - BACK BARN	41.93
	4289591251	WR - CHEMICAL ROOM	40.66
TOTAL FOR: MICHIGAN GAS UTILITIES CORP			<u>1,947.40</u>
000024	METTLER TOLEDO		
	655087601	CALIBRATION OF LAB SCALE	345.30
TOTAL FOR: METTLER TOLEDO			<u>345.30</u>
000034	VERIZON		
	9915435418	DPW/WR - ALARM SERVICE 8/11-9/10/2022	55.47
TOTAL FOR: VERIZON			<u>55.47</u>
000035	APPLIED INNOVATION		
	2042273	ADMIN - CITY HALL COPIER CHARGES 8/13 - 9/12/2022	310.36
	2045065	DPW - RICOH COPIER 8.16 - 9.15.2022	75.63

TOTAL FOR: APPLIED INNOVATION			385.99
000138	AMERICAN OFFICE SOLUTIONS		
	32394894	DPS - COPIER LEASE & USAGE AUGUST 2022	143.64
TOTAL FOR: AMERICAN OFFICE SOLUTIONS			143.64
000153	FLEIS & VANDENBRINK INC		
	63343	WRP SURCHARGE EVALUATION 7/31/ - 8/27/2002	1,200.00
	63554	WELL 4 CHEMICAL FEED DESIGN AND PERMITTING	382.58
TOTAL FOR: FLEIS & VANDENBRINK INC			1,582.58
000499	CITY OF OTSEGO		
	0000002450	PUBLIC ACCURACY NOTICE AUGUST 2022	48.00
TOTAL FOR: CITY OF OTSEGO			48.00
000531	CUMMINS SALES AND SERVICE		
	S3-54716	WR - PM SERVICE 12TH ST	572.50
	S3-54718	WR - PM SERVICE CUSHMAN STATION	525.45
	S3-54735	WR - PM SERVICE WR PLANT	752.53
TOTAL FOR: CUMMINS SALES AND SERVICE			1,850.48
000624	AIS CONSTRUCTION-JOHNDEERE POWERPLN		
	88002-52072	DPW - WEAR BAR FOR LOADER BUCKET BN	1,026.64
	G62254	WR - LOADER BREAK DOWN	1,026.64
TOTAL FOR: AIS CONSTRUCTION-JOHNDEERE POWERPLN			2,053.28
000714	WEBB CHEMICAL SERVICE CORP		
	544387	WR - FERRIC CHLORIDE SOLUTION 17391#	8,321.40
TOTAL FOR: WEBB CHEMICAL SERVICE CORP			8,321.40
000897	SHERWIN WILLIAMS		
	2601-4	WR - 15 5 GALLON BUCKETS PAINT BP	983.85
TOTAL FOR: SHERWIN WILLIAMS			983.85
000941	WEST MICHIGAN CRIMINAL JUSTICE TC		
	4911	DPS - DE-ESCLATION TRAINING	200.00
TOTAL FOR: WEST MICHIGAN CRIMINAL JUSTICE TC			200.00
000947	WYOMING ASPHALT PAVING INC.		
	2022-527	DPW - 601 TONS TOP WALNUT WOODS	36,181.20
TOTAL FOR: WYOMING ASPHALT PAVING INC.			36,181.20
001413	NCL OF WISCONSIN		
	476594	WR - LAB SUPPLIES	445.61
TOTAL FOR: NCL OF WISCONSIN			445.61
001829	PERCEPTIVE CONTROLS INC		

	15629	WR - DIGESTER PLC UPGRADE	5,920.00
	6984	DPW - REPLACE WATER METER AT 12TH ST APT	583.75
TOTAL FOR: PERCEPTIVE CONTROLS INC			6,503.75

001921	MICHIGAN MUNICIPAL LEAGUE		
	2022.09	MEMBERSHIP RENEWAL 11/01/2022 - 10/31/2023	2,910.00
TOTAL FOR: MICHIGAN MUNICIPAL LEAGUE			2,910.00

002030	DRUG SCREEN PLUS INC		
	22JUL1339	DPW - RANDOM DRUG SCREEN 7.1 - 7.31.2022	45.00
TOTAL FOR: DRUG SCREEN PLUS INC			45.00

002116	CHARTER COMMUNICATIONS		
	0005188090122	DPW/WR - INTERNET SEPTEMBER 2022	139.98
	0036867090722	AIRPORT - INTERNET SERVICE 09/07 - 10/06/2022	84.00
	0054103090522	CITY HALL PHONES/INTERNET 09/05 - 10/04/2022	499.45
TOTAL FOR: CHARTER COMMUNICATIONS			723.43

002281	HOME DEPOT		
	4022405	DPW - MILL WINDOWS AS	285.63
	5022230	DPW - TRUCK #19	11.17
	5022289	DPW - MILL WINDOWS AS	271.95
	5022290	DPW - MILL WINDOWS AS	174.01
	9021819	DPW - GARBAGE CORRAL DR	103.74
	9021863	DPW - GARBAGE CORRAL OLD CITY HALL DR	17.62
TOTAL FOR: HOME DEPOT			864.12

002368	ORTON, TOOMAN, HALE, MCKOWN & KIEL		
	2022.08.31	DPS - LEGAL SERVICES JUNE, JULY, AUGUST 2022	662.50
TOTAL FOR: ORTON, TOOMAN, HALE, MCKOWN & KIEL			662.50

002371	RENEWED EARTH INC		
	30786	DPW - YARD BLEND FOR STUMP REPAIR	123.75
TOTAL FOR: RENEWED EARTH INC			123.75

002582	PLAINWELL REDI MIX - COSGROVE ENT.		
	1014	DPW - SIDEWALK COLFAX NEAR GILKEY	377.50
	1074.	DPW - SIDEWALK COLFAX BY GILKEY	663.50
	1075	DPW - SIDEWALKS S ANDERSON/COLFAX	949.50
	1076	DPW - S ANDERSON	890.00
TOTAL FOR: PLAINWELL REDI MIX - COSGROVE ENT.			2,880.50

002650	FUEL MANAGEMENT SYSTEM		
	173558	DPS - FUEL/DIESEL POLICE 9/1 - 9/15/2022	856.22
TOTAL FOR: FUEL MANAGEMENT SYSTEM			856.22

002703	CONTINENTAL LINEN SERVICES INC		

	3392103	DPW - UNIFORMS AND RUGS	58.50
	3392104	WR - UNIFORMS AND RUGS	29.43
	3397912	DPW - RUGS AND UNIFORMS	32.49
	3397913	WR - UNIFORMS	13.35
	3403759	CITY HALL RUGS	28.62
TOTAL FOR: CONTINENTAL LINEN SERVICES INC			162.39

004190	WATERSOLVE LLC		
	9474	WR - SOLVE 137 465LB DRUM	1,100.00
TOTAL FOR: WATERSOLVE LLC			1,100.00

004198	QUALITY CYLINDER SERVICES LLC		
	3424	DPW - PULL PAVER CYLINDER SEAL REPAIR BN	54.28
TOTAL FOR: QUALITY CYLINDER SERVICES LLC			54.28

004241	GHD SERVICES INC		
	340-0043412	UTILITIES/Common Area Maint for July 2022	1,289.12
TOTAL FOR: GHD SERVICES INC			1,289.12

004796	SILVERSCRIPT INSURANCE COMPANY		
	2022.09TOWN	RETIREE PRESCRIPTION COVERAGE SEPTEMBER 2022 - TC	26.60
	2022.09WHIT	RETIREE PRESCRIPTION COVERAGE SEPTEMBER 2022 - W	26.60
TOTAL FOR: SILVERSCRIPT INSURANCE COMPANY			53.20

004852	PACE ANALYTICAL SERVICES LLC		
	2250199220	WR - PACE ANALYTICAL SAMPLES 9/9/2022 BP	584.92
TOTAL FOR: PACE ANALYTICAL SERVICES LLC			584.92

004855	PLAINWELL ACE HARDWARE		
	11291	DPW - PARTS FOR #152	31.73
	11296	DPW - PARTS/FITTINGS #152	48.14
	11313	DPW - HYDRANT REPAIR	1.70
	11314	ADMIN OFFICE TAPE MEASURE	7.99
	11331	DPW - WALNUT WOODS SUPPLIES CP	33.57
	11336	DPW - ASPHALT TOOLS WK	165.89
	11350	DPW - GARBAGE CORRAL MISC FASTENERS	16.20
	11353	DPW - GARBAGE CORRAL FASTNERS	7.00
	11354	DPW - GRASS MIX JF	109.99
	11357	DPW - GARBAGE CORRAL BOLTS	52.00
	11359	DPW - AIRPORT MAINT AB	16.98
	11364	DPW - PLAQUE FOR RANSOM LIBRARY	34.16
	11378	WR - BUILDINGS & GROUNDS SUPPLIES BP	63.98
	11379	DPW - COOK BATHROOM AUGER JF	12.99
	11392	WR - THERMOMETER & BATTERY BP	44.58
	11393	WR - HOSE FITTINGS BP	37.95
	11394	WR - CREDIT FOR THERMOMETER RETURN	(21.00)
	11400	DPW - WATER MAIN BREAK REPAIR S ANDERSON	99.14

	11401	DPW - WATER MAIN BREAK REPAIR S ANDERSON	7.99
	11412	DPW - TRUCK 5 PARTS STORAGE WK	13.18
TOTAL FOR: PLAINWELL ACE HARDWARE			784.16

004858	FERGUSON WATERWORKS		
	0163144	DPW - MANHOLE RISER RING WALNUT WOODS	323.97
TOTAL FOR: FERGUSON WATERWORKS			323.97

004894	ASCENSION MI EMPLOYER SOLUTIONS		
	481273	ADMIN - NEW HIRE SCREEN - BRANCH	116.00
TOTAL FOR: ASCENSION MI EMPLOYER SOLUTIONS			116.00

004902	BLOOM SLUGGETT PC		
	23028	LEGAL SERVICES AUGUST 2022	4,142.00
TOTAL FOR: BLOOM SLUGGETT PC			4,142.00

005011	SAFEGUARD BUSINESS SYSTEMS		
	035115152	ADMIN - NEW CHECK STOCK AND DEPOSIT SLIPS	416.91
TOTAL FOR: SAFEGUARD BUSINESS SYSTEMS			416.91

005012	UNITED BANK		
	2022.09.13	ACH FEE - PAYROLL DIRECT DEPOSIT	7.00
	2022.09.15	ACH FEES - TAX DISTRIBUTION/UNION DUES/UTILITY PYM	21.00
	2022.09.19	ACH FEE - TAX DISTRIBUTION	7.00
TOTAL FOR: UNITED BANK			35.00

005015	CHECKALT-KLIK		
	194022	ELOCKBOX FEES FOR AUGUST 2022	150.13
TOTAL FOR: CHECKALT-KLIK			150.13

005025	ZEINSTRA GREENHOUSE		
	020603	DPW FLOWERS FOR SPRING PLANTING 2022	3,243.00
TOTAL FOR: ZEINSTRA GREENHOUSE			3,243.00

005032	M & C REPAIR LLC		
	11085	DPW - TRUCK REPAIRS 2006 GMC TRANSMISSION	9,229.99
TOTAL FOR: M & C REPAIR LLC			9,229.99

005041	EVOQUA WATER TECHNOLOGIES		
	905511448	WR - AUGUST 2022 ODOR CONTROL	300.00
TOTAL FOR: EVOQUA WATER TECHNOLOGIES			300.00

005047	STAPLES, INC.		
	3515930182	DPS - CLEANING SUPPLIES	38.75
	3516590884	ADMIN - GENERAL SUPPLIES JS	118.87
	3516590885	WR - TONER CARTRIDGE BP	197.99
TOTAL FOR: STAPLES, INC.			355.61

005057	MICHIGAN AMMO LLC		
	2236	DPS - BRASS RETURN FOR CREDIT	(239.40)
	2239	DPS - AMMO FOR TRAINING	725.00
TOTAL FOR: MICHIGAN AMMO LLC			485.60
005092	CERTASITE LLC		
	12488739	FIRE SUPPRESION REPAIRS CRISPE HOUSE	1,747.84
TOTAL FOR: CERTASITE LLC			1,747.84
005095	VITAL RECORDS CONTROL		
	0527632	ADMIN - CITY HALL SHREDDING	71.42
TOTAL FOR: VITAL RECORDS CONTROL			71.42
005114	ASPHALT RESTORATION INC		
	10537	DPW - CRACK FILLING MAIN ST TO NORTH POINT DR	13,974.80
	10537.	DPW - CRACK FILLING PRINCE ST STARTING AT BRIDGE	3,499.00
TOTAL FOR: ASPHALT RESTORATION INC			17,473.80
ACACH	ALLEGAN COUNTY TREASURER		
	2022.09.10	2022 TAX COLLECTIONS W/E 09/10/2022	2,915.66
	2022.09.17	2022 TAX COLLECTIONS W/E 09/17/2022	3,431.16
TOTAL FOR: ALLEGAN COUNTY TREASURER			6,346.82
ALLEG ISD	ALLEGAN AREA EDUCATION SVC AGENCY		
	2022PILOT	PILOT DISTRIBUTION AAESA	5,226.20
TOTAL FOR: ALLEGAN AREA EDUCATION SVC AGENCY			5,226.20
ALLEGAN TR	ALLEGAN COUNTY TREASURER		
	2022PILOT	PILOT DISTRIBUTION 2022 COUNTY	7,477.38
TOTAL FOR: ALLEGAN COUNTY TREASURER			7,477.38
CBEFT	HUNTINGTON NATIONAL BANK		
	2022.09.09	AUGUST 2022 HUNTINGTON BANK CHARGES	30.00
TOTAL FOR: HUNTINGTON NATIONAL BANK			30.00
PL COM SCH	PLAINWELL COMMUNITY SCHOOLS		
	2022PILOT	PILOT DISTRIBUTION 2022 PLAINWELL SCHOOL DEBT	11,353.35
TOTAL FOR: PLAINWELL COMMUNITY SCHOOLS			11,353.35
RANSOM	RANSOM DISTRICT LIBRARY		
	2022PILOT	PILOT DISTRIBUTION 2022 PILOT	2,396.47
TOTAL FOR: RANSOM DISTRICT LIBRARY			2,396.47
RDLACH	RANSOM DISTRICT LIBRARY		
	2022.09.10	2022 TAX COLLECTIONS W/E 09/10/2022	383.66
	2022.09.17	2022 TAX COLLECTIONS W/E 09/17/2022	451.49

TOTAL - ALL VENDORS

150,612.97

INVOICE AUTHORIZATION

Person Compiling Report

I verify that to the best of my knowledge the attached invoice listing is accurate and the procedures in place to compile this invoice listing has been followed.

Insert Signature:

Roxanne Branch
Digitally signed by Roxanne Branch
 Date: 2022.09.22 14:18:57 -04'00'

Brian Kelley, Finance Director/Treasurer

I verify that I have reviewed the expenditures attributed to my department and to the best of my knowledge the attached invoice listing is accurate and complies with the City's purchasing policy.

Insert Signature:

Brian Kelley
Digitally signed by Brian Kelley
 Date: 2022.09.22 16:51:25 -04'00'

Bryan Pond, Water Renewal Plant Supt.

I verify that I have reviewed the expenditures attributed to my department and to the best of my knowledge the attached invoice listing is accurate and complies with the City's purchasing policy.

Insert Signature:

Bryan Pond
Digitally signed by Bryan Pond
 Date: 2022.09.23 08:06:02 -04'00'

Kevin Callahan, Public Safety Director

I verify that I have reviewed the expenditures attributed to my department and to the best of my knowledge the attached invoice listing is accurate and complies with the City's purchasing policy.

Insert Signature:

Bob Nieuwenhuis, Public Works Supt.

I verify that I have reviewed the expenditures attributed to my department and to the best of my knowledge the attached invoice listing is accurate and complies with the City's purchasing policy.

Insert Signature:

Robert Nieuwenhuis
Digitally signed by Robert Nieuwenhuis
 Date: 2022.09.22 14:38:40 -04'00'

Erik J. Wilson, City Manager

I verify that I have reviewed the expenditures attributed to my department and to the best of my knowledge the attached invoice listing is accurate and complies with the City's purchasing policy.

Insert Signature:

Erik Wilson
Digitally signed by Erik Wilson
 Date: 2022.09.22 16:20:45 -04'00'



September 8, 2022

**Board of Commissioners Update
Administrator's Report**

ENGAGEMENT

Employment (Last Updated on August 25, 2022)
2022 as of Q2:

TURNOVER/RETENTION (Regular FT & PT Only)	Q1	Q2	Q3	Q4
# of Terminations (includes Retirees)	16*	9*		
Average length of tenure of terminated REG employees	16.48	9.79		
Turnover % of new REG employees (<=1 year)	16%	21%**		
Turnover % of REG employees	4.10%	2.20%		
Total average number of REG Employees	393	401		
Notes	*9 of the terminations were retirements	*1 termination was a retirement. **calculation updated/changed in Q2 for both quarters		
RECRUITMENT	Q1	Q2	Q3	Q4
Jobs Posted	10	12		
# of Days to Hire (KPI)	53.6	51.21		
# of New Hires	25	37		
# of Promotions or Transfers	15	7		

Current Number of Active Regular Full-Time and Regular Part-Time Employees: 404

New Hires: 2

Last Name	First Name	Position	Department
Gillentine	David	Corrections Officer	Sheriff's Office – Corrections
Neal	Tabitha	Legal Administrative Specialist	Prosecuting Attorney

Left Employment: 1

Last Name	First Name	Position	Department
Marklevitz	Emily	Telecommunicator	Central Dispatch

Promotions/Transfers: 0

Current Open Positions: 15

Position	Department	Current Status
Academy Sponsored Cadet	Sheriff's Office	Unfilled
Assistant Public Defender	Public Defender	Unfilled – 2023 position approved to fill early
Chief Assistant Public Defender	Public Defender	Unfilled
Corrections Officer	Sheriff's Office – Corrections	Unfilled
Corrections Officer	Sheriff's Office – Corrections	Unfilled
Corrections Officer	Sheriff's Office – Corrections	Unfilled
Corrections Officer	Sheriff's Office – Corrections	Unfilled
Deputy Circuit Court Clerk (PT25)	County Clerk	Will remain unfilled until 2023
Deputy Drain Development Coordinator	Drain Office	Unfilled
Drain Maintenance Technician	Drain Office	Unfilled
GIS Specialist II	Information Services	Unfilled
IRPT Janitor	Facilities	Unfilled
Program Coordinator	Transportation	Unfilled
Senior Services Counselor	Senior and Veteran Services	Internal candidate – transfer date to be determined
Telecommunicator	Central Dispatch	Unfilled
Telecommunicator	Central Dispatch	Unfilled

For more information regarding this matter, please contact Lyn Holoway, Human Resources Manager at (269) 673-0537 or lholloway@allegancounty.org.

OPERATIONS

Facility Master Planning (Last Updated on August 25, 2022) – Interviews and office visits with Courthouse leadership concluded on August 24. The process went very smoothly and Wightman was able to gather a wealth of information to assist their analysis of the building. The second phase is to gather similar information with respect to the County Services Building over the next 30 days. From there, Wightman should have all the information they need to begin performing their comprehensive analysis of both buildings. For more information regarding this matter, please contact Steve Sedore, Executive Director of Operations, at (269) 673-0373 or ssedore@allegancounty.org.

Peninsula Fiber Network (PFN) Project – On Thursday, August 18, 2022, AT&T cut its last end office phone switch in Allegan County over to Peninsula Fiber Network (PFN) which kicked off a 30-day monitoring period of incoming 911 call provider data to ensure the final cut was successful and no AT&T lines were missed. After this 30 burn-in period Allegan County will be officially cut over to PFN for all 911 call routing to the Dispatch Center and AT&T will turn off all of its old 911 trunks that previously served Allegan County. Concurrent to the cutover, on August 17, PFN's subcontractor Roese Contracting Co Inc. began the "last mile" installation of PFN's new fiber optic run to Central Dispatch. Once the new fiber installation and subsequent 30-day burn-in period are complete, the PFN Project that began in 2018 will be finished. The move to PFN provides Allegan County Central Dispatch with a Next-Generation

Fiber backbone for 911 call handling that included enhanced location services, redundant paths of service, text to 911, and a myriad of other future capabilities for 911 call handling. For more information regarding this matter, please contact Jeremy Ludwig, Director of Central Dispatch at (269) 686-5211 or jludwig@allegancounty.org.

Courthouse and Youth Home Carpeting (Last Updated on June 9, 2022) – The contractor has received the carpet tiles from the manufacturer and the team is working closely with them to finalize an installation schedule during the weeks of September 5 and September 12. Installation in the Courthouse will take place after hours, likely in sections over multiple days. The Youth Home courtroom will occur during the day as it is a smaller space and easier to work around the court schedule. For more information regarding this matter, please contact Carl Chapman, Facilities Management Director, at (269) 673-0207 or cchapman@allegancounty.org.

Animal Shelter Projects (Last Updated on August 25, 2022) – On August 26, the County held a quarterly animal shelter meeting. During this discussion, new information related to the designated shelter projects was presented. Below is an updated list of the identified projects for the Shelter.

- **Modular Surgical Shelter** – Wishbone reported that their preliminary estimates for a new surgical shelter were near \$600,000, far beyond their originally anticipated costs for this project. This cost is based on a 3,000-3,200 sq. ft. structure, which is much larger than the original space identified in 2019 which generated estimates of \$250,000. As a result, Wishbone requested the project be delayed for 12 months as they revisit their strategy for this level of service. The County agreed to continue working with Wishbone for the next year assisting where appropriate.
- **Old shelter demolition** – The County is scheduling demolition for approximately 12 months out.
- **New shelter garage cleanup** – To restore the safety and security in transitioning animals from the Sheriff's Department Animal Control team into the shelter, the County is working with Wishbone to remove equipment currently impeding the Control Officer from driving their vehicle into the garage bay.
- **Play area and Kennels** – This project will proceed with the installation of fencing on the west side of the building once the septic system has been remediated.
- **Tile Floor Replacement** – The County will continue to maintain, clean, and repair the current floor and reconsider this capital project in 2024.

For more information regarding this matter, please contact Carl Chapman, Facilities Management Director, at (269) 673-0207 or cchapman@allegancounty.org.

FINANCIAL STABILITY

Additional Source of Grant Funds – The Federal Emergency Management Agency (FEMA) provides assistance for the response, recovery, and mitigation of disasters. On March 27, 2020, the President declared a major disaster for the State of Michigan (FEMA-4494-DR) in response to the COVID-19 pandemic. At that time, FEMA reimbursed expenditures at a 75% rate, and the local unit would need to provide the other 25%. Because the County's COVID response needs were being met by other grants that provided 100% funding, there was no need to request FEMA public assistance at that time. To ensure that the County retained its options, though, a Request for Public Assistance (RPA) was filed with FEMA in April of 2020. The RPA functions as notice of an intent to apply; no project or costs needed to be identified at that time. Recently, FEMA amended their public assistance reimbursement to 100% for COVID-19 costs that occurred on or before July 1, 2022, and established a deadline of December 31, 2022, to claim those costs. In addition, costs incurred after July 1, 2022, may be eligible for 90% FEMA reimbursement, with no end date announced. As other grant sources are phased out, require local match amounts, or simply do not cover all of the County's expenses, this is an opportunity for an alternate source of funds. Staff is coordinating with other departments to identify COVID-19 expenditures that have not been covered by other granting sources, with particular attention being paid to Public Health expenditures. For more information regarding this matter, please contact Lorna Nenciarini, Executive Director of Finance at (269) 673-0228, or lnenciarini@allegancounty.org.

SERVICES

Senior Day at the Fair – On Tuesday, September 13, 2022, the COA will be serving pancakes. There will be vendors with community resources, music, and BINGO. The Health Department will be offering Hepatitis A and COVID vaccines. The event runs from 8 am – 12 pm in the tent on the hilltop. For more information regarding this matter, please contact Sherry Owens a (269) 686-5144 or sowens@allegancounty.org.

Veterans Day at the Fair – On Thursday, September 15, 2022, Veteran Services will be at the fair to provide Veterans with information and address any questions on services. For more information regarding this matter, please contact Sherry Owens at (269) 686-5144 or sowens@allegancounty.org.

Allegan County Fair Booth Project – During this year's Allegan County Fair (September 9 – 17, 2022), the County will once again be participating in the Agricultural Society Fair Exhibit. Service areas throughout the County will be displaying their marketing materials, such as brochures, pamphlets, and maps for the purpose of educating residents, visitors, and employees on what is available and where to locate services. This booth comes from a continuous improvement idea from the County Expo back in 2014/15 as a way of expanding the County's exposure by participating in the County Fair. Over the last eight years, the County has placed in the top ten and earned prize money, which is used by the Engagement Team for projects such as recognition program prizes, luncheons, and appreciation events. This year's theme is *Making Memories* together. If you visit this year's fair, please stop by and check out the booth. For more information regarding this matter, please contact Brandy Gildea, Parks Manager at (269) 673-0378 or bgildea@allegancounty.org.

Bysterveld Trail Improvements – The 2022 Capital Improvement Project (CIP) to improve Bysterveld Trails has been completed. The existing gravel trails were power raked to loosen materials angling to the center. Fresh 22A crushed concrete at a thickness of 3-5 inches has been laid over the top being crowned in the middle to improve drainage. The sides of the path, followed by the center were then compacted. These improvements will help eliminate the low wet spots and improve overall drainage and accessibility.

CIP funds from the Parks annual asphalt maintenance plan will also be used to crack seal all the asphalt paths located in Bysterveld Park and New Richmond Park. For more information regarding this matter, please contact Brandy Gildea, Parks Manager at (269) 673-0378 or bgildea@allegancounty.org.



Volunteer Driver Appreciation Day – County Mobility Management is committed to promoting the independence of seniors and individuals with disabilities by offering rides to medical and nutritional appointments, legal appointments, shopping, and errands. Currently, there are 9 volunteer drivers who transport seniors (60 & over) and persons with disabilities. July was a busy month - the volunteer drivers provided 233 trips and drove over 11,000 miles. Allegan County Transportation will hold the annual Volunteer Driver Appreciation Day for drivers on September 22, 2022. The day will include a training presentation from the Sheriff's Office on driving safety, vehicle inspections, car washes, and lunch. Volunteer Driver Appreciation Day is a collaborative initiative between several service areas, including Transportation, Cheever Youth Home, the Sheriff's Department, and Senior Services. For more information regarding this matter, please contact Whitney Ehresman, Transportation Director at (269) 686-4529 or WEhresman@allegancounty.org.

COVID-19 Update (Last Updated on August 25, 2022) – The latest COVID-19 update from Public Health is attached (Attachment A). For more information regarding this matter, please contact Angelique Joynes, Health Officer, at ajoynes@allegancounty.org.

Environmental Health Field Team Service Delivery Update (Last Updated on August 25, 2022) – Currently, 99% of the eligible applications, received through August 7, were issued within the timeframe (7/25/2022 –8/7/2022), the 14 business day benchmark, attachment B. 98% of all customers (8/8/2022 – 8/21/2022) were contacted within 5 business days of submitting their application. For more information regarding this matter, please contact Randy Rapp, Environmental Health Manager at (269) 686-4506.

Water Study Workgroup (Last Updated on August 25, 2022) – The next meeting is scheduled for September 7, 2022. For more information, please contact Randy Rapp, Environmental Health Manager at (269) 686-4506.

Broadband Action Workgroup (Last Updated on August 25, 2022) – The Broadband Action Workgroup (workgroup) last met on July 21, 2022; minutes will be posted to the meeting when available. The workgroup did not hold August meetings and will not meet again until after the bids are received. The bids are due back for our request for proposal (RFP) on Friday, September 16, 2022.

To date, around 1,970 broadband survey responses have been received. The survey will continue to be available through early 2023 to collect speed test data. The next meeting is scheduled for October 6, 2022. For more information regarding this matter, please contact Jill Dunham, Project Manager, at (269) 673-0588.



COVID-19 AND OTHER EMERGING PUBLIC HEALTH TOPICS

BOARD OF COMMISSIONER UPDATE

SEPTEMBER 8, 2022

Data as of September 5, 2022

CONTENTS

EXECUTIVE SUMMARY	2
COVID-19 MITIGATION COMPONENTS	2
ENHANCED ABILITY TO TEST	3
COUNTY-LEVEL DATA AS OF AUGUST 29, 2022	3
TEST AVAILABILITY	3
ROBUST CASE INVESTIGATION AND CONTACT TRACING	4
ALLEGAN COUNTY COVID-19 COMMUNITY LEVEL: LOW	4
OVERVIEW OF COVID-19 CASES AND DEATHS IN THE LAST TWO WEEKS (8/19/2022 to 9/1/22)	4
CASE INVESTIGATION	5
EXPOSURE LETTERS AND CLOSE CONTACTS	6
OUTBREAKS & CLUSTERS IN ALLEGAN COUNTY	6
LONG TERM CARE & OTHER CONGREGATE CARE FACILITIES	6
SUFFICIENT HEALTH CARE CAPACITY	7
HOSPITALIZATIONS	7
DEATHS (7 DAY AVERAGE)	7
BEST PRACTICES	8
SCHOOLS	8
MONKEYPOX (MPV)	8
BUSINESSES	8
MONKEYPOX (MPV)	8
COMMUNICATIONS	8
BIRD OWNERS ENCOURAGED TO CONTINUE PRACTICING BIOSECURITY MEASURES TO PROTECT BIRDS FROM HPAI.....	8
COMMUNITY VACCINATION/HERD IMMUNITY/TREATMENT	9
UPDATED COVID-19 BIVALENT BOOSTERS FOR THOSE 12 YEARS OF AGE AND UP	9
COVID-19 VACCINE COVERAGE.....	10
VACCINATION COVERAGE BY AGE GROUP	10
VACCINATION COVERAGE BY ZIP CODE	10
VACCINE AVAILABILITY.....	11
VACCINE EFFECTIVENESS (VE).....	11
LOCAL HEALTH DEPARTMENT (LHD) BREAKTHROUGH DATA DISTRIBUTION.....	11
COVID-19 SURVEILLANCE	11
EPIDEMIOLOGIC SURVEILLANCE	14
SOURCES	16
APPENDICES	17

EXECUTIVE SUMMARY

The following report contains COVID-19-related data from **August 19, 2022, to September 1, 2022**, on the 5 mitigation components Allegan County Health Department (ACHD) previously identified. This report contains local COVID-19 data for Allegan County, information on vaccination data, wastewater surveillance, emerging variant updates, and other resources regarding COVID-19 mitigation. This report also contains epidemiological surveillance and health education on other ongoing and emerging public health topics including monkeypox (MPV), and other regional epidemiological topics at a glance. ACHD continues to monitor local, statewide, and global COVID-19 data, and continues to follow the Michigan Department of Health and Human Services (MDHHS) and the Centers for Disease Control and Prevention (CDC) recommendations.

We are currently evaluating what local data is not available through other entities that help people evaluate individual risks and reviewing website analytics to help determine if these reports are helpful for community members. More information is to come on the future of these updates.

WHAT'S NEW AT A GLANCE:

- Updated bivalent boosters for those 12 years of age and older: the CDC issued new recommendations for COVID-19 boosters, after the FDA authorized updated booster formulas from both Pfizer and Moderna.
- Allegan County COVID-19 Test Positivity Rate is trending **downward**.
- Weekly COVID-19 cases have **decreased** by more than 30% since the 8/9/2022 to 8/15/2022 reporting period.
- MDARD is encouraging residents and bird owners to continue practicing biosecurity measures to help prevent HPAI as wild birds begin to migrate.

An overview of COVID-19 data in Allegan County from **8/19/22 to 9/1/22** can be found in the graphic below:

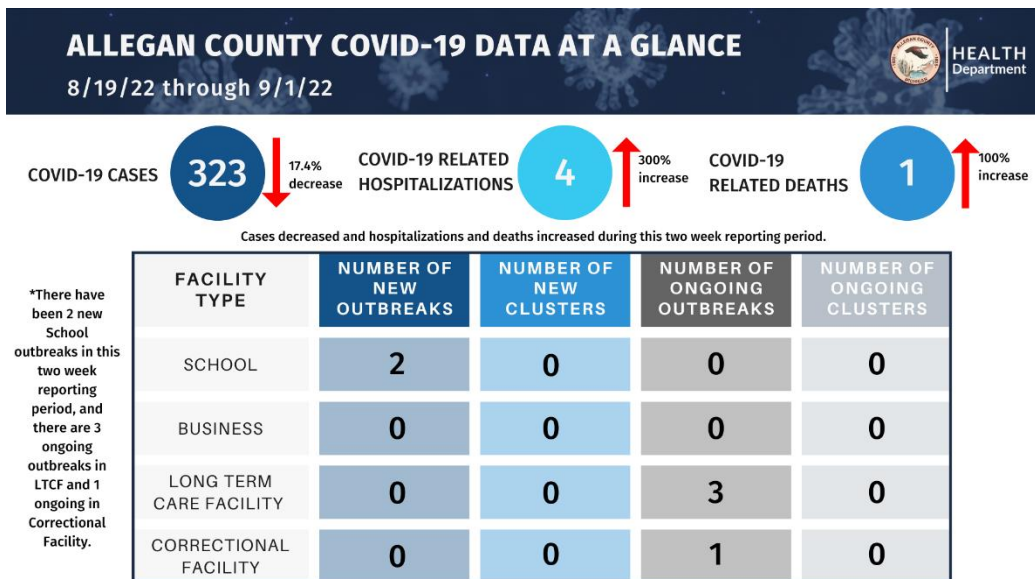

Previous BOC reports that may include background information for some of the topics discussed in this current report can be found [here](#).

COVID-19 MITIGATION COMPONENTS



Allegan County currently is at a low community transmission level for COVID-19. **ACHD continues to recommend the following:**

- Staying up-to-date on your COVID-19 vaccines
- Getting tested if you have symptoms, before and after traveling, and before gathering with others.

Allegan County COVID-19 Community Level: Low

Allegan County Health Department recommends everyone to:

Stay up to date on your COVID-19 Vaccines

Get tested if you have symptoms

Actions including social distancing, frequent handwashing, wearing a well-fitted face mask, and isolation/quarantine help lessen the level of transmission

Learn more about CDC's COVID-19 Community Levels [here](#).

#DoYourPart

COVID-19 Community Levels are a tool to help communities decide what prevention steps to take based on the latest data. These Community Levels can be low, medium, or high and **are determined by looking at hospital bed utilization, hospital admissions, and the total number of new COVID-19 cases in an area.** Find more about COVID-19 Community Levels [here](#).

COVID-19 Community Levels in Michigan

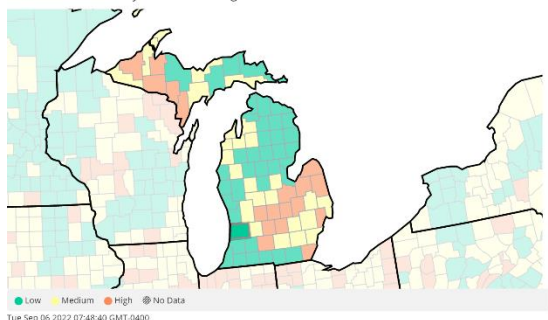

Note: Counties surrounding Allegan County may be in a medium or high COVID-19 Community Level. If you work or visit other counties often, make sure to take precautions to protect yourself and others such as wearing a mask, washing your hands often, staying home if you feel sick, and social distancing when possible.

Use the CDC's [COVID-19 County Check tool](#) to find out what community level the county you will be visiting is in.

ENHANCED ABILITY TO TEST

COUNTY-LEVEL DATA AS OF AUGUST 29, 2022

✓ **Test Results**
Aug 23 - Aug 29

19.2% positive tests

612.3 daily tests administered per million

1 week ⓘ
Aug 19 - Aug 26

Data Takeaway: The Test Positivity Rate for Allegan County is trending **downward**, after trending upward the week prior. We've seen this trend pattern for the past 4 weeks, with cases trending upward, then downward.



At this stage of the pandemic, percent positivity alone is no longer a strong indicator of the total number of individuals who tested positive, due to several factors – one being at-home testing. It is best to evaluate percent positivity with another metric, such as COVID-19 concentration levels in wastewater, to get a more accurate idea of the prevalence of the virus

in an area. **The 7-day positivity rate for Allegan County as of August 29 was 19.2% with 612.3 daily tests administered per million. This indicates a 5.7% decrease in the 7-day positivity compared to the 8/9/2022 to 8/15/2022 reporting period, which had 526.8 daily tests administered per million.**

TEST AVAILABILITY

Data as of September 5, 2022

At this time, at-home tests are not reported in the Michigan Disease Surveillance System (MDSS) and therefore, are not included in the test positivity rates or case counts. **See the Appendix for a list of testing resources available to community members.**



ROBUST CASE INVESTIGATION AND CONTACT TRACING

ALLEGAN COUNTY COVID-19 COMMUNITY LEVEL: LOW

New Cases
Aug 23 - Aug 29

125.3
weekly cases per 100,000 population

148
weekly cases

As of 8/29/2022, Allegan County remained at a low COVID-19 community level based on the CDC framework. **Data Takeaway: Models showed a decrease in cases compared to the 8/9/2022 to 8/15/2022 reporting period.**

During the period 8/23/2022 to 8/29/2022, Allegan County's new weekly case rate was 125.3 per 100,000 population with 148 weekly cases.

Weekly cases decreased by more than 30% since the 8/9/2022 to 8/15/2022 reporting period (182.9 per 100,000 - 216 total weekly cases).

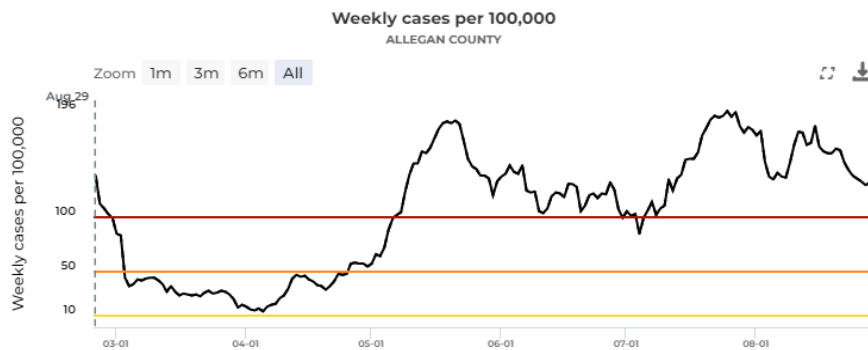

OVERVIEW OF COVID-19 CASES AND DEATHS IN THE LAST TWO WEEKS (8/19/2022 to 9/1/22)

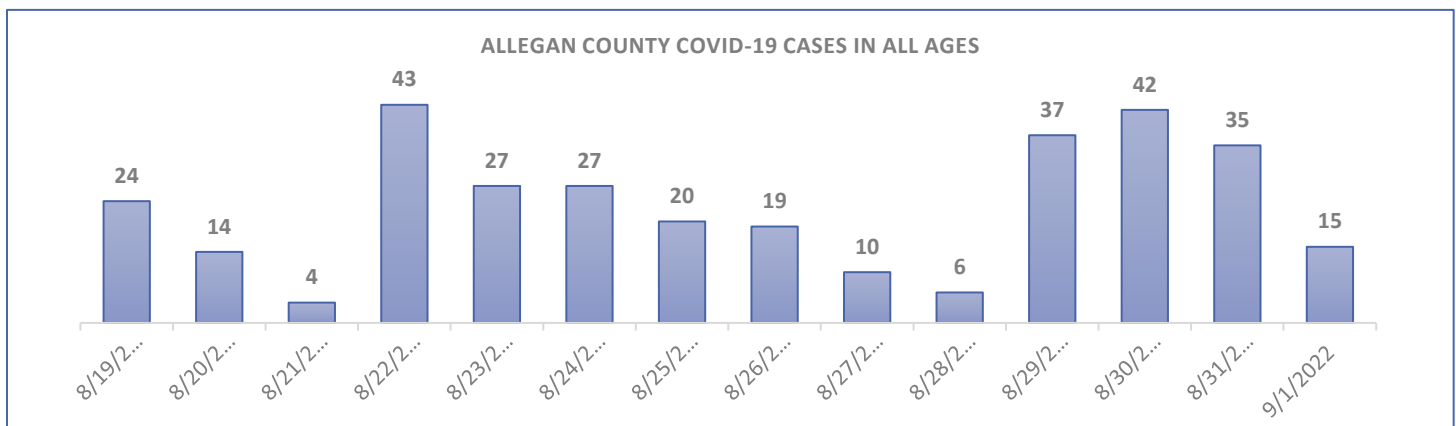

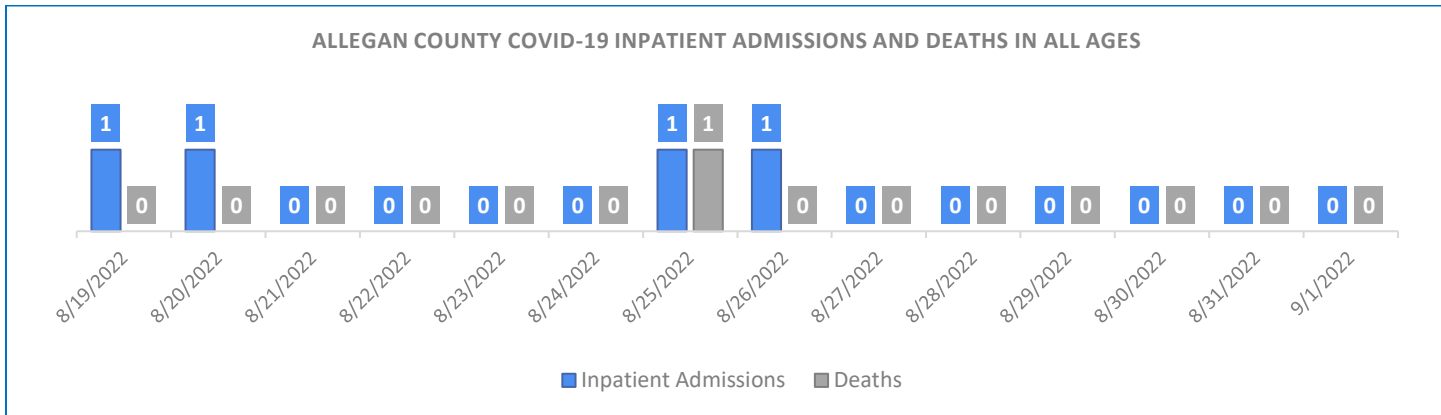

DURING 8/19/2022 to 9/1/22 FOR ALLEGAN COUNTY:

- **323 total cases** were reported via the Michigan Disease Surveillance System (MDSS)
 - o 231 confirmed cases and 92 probable cases related to SARS-CoV2 infection as reported
- 2.2% of the cases were reported as asymptomatic
- 38.4% of cases were reported as ‘vaccine breakthrough’ cases, which has decreased from the previous two weeks
- **Four reported hospitalizations¹** related to SARS-CoV-2 infection
- There was **one death** related to SARS-CoV-2 infection
- 5% of the cases were reported to be related to international, domestic, and/or in-state travel
- From 8/18/2022 to 8/31/2022, positivity rate² was a reported 22.0%

ACHD continues to monitor the COVID-19 metrics for hospitalizations and deaths as this can show the risk of a medically significant COVID-19 variant or healthcare system strain.

CASE INVESTIGATION³

ACHD is currently working to investigate all communicable disease cases. Prioritized groups for case investigation, when applicable, include individuals over the age of 65, school-aged individuals, and individuals that live or work in congregate care settings. During the case investigation process, ACHD works to ensure all basic needs are being met for individuals and their families. All cases receive a Patient Education Genius (PEG) notification that is provided via email or text messages for a case investigation form.

CASES IN THE LAST TWO WEEKS, BY AGE GROUP (8/19/2022 to 9/1/22)

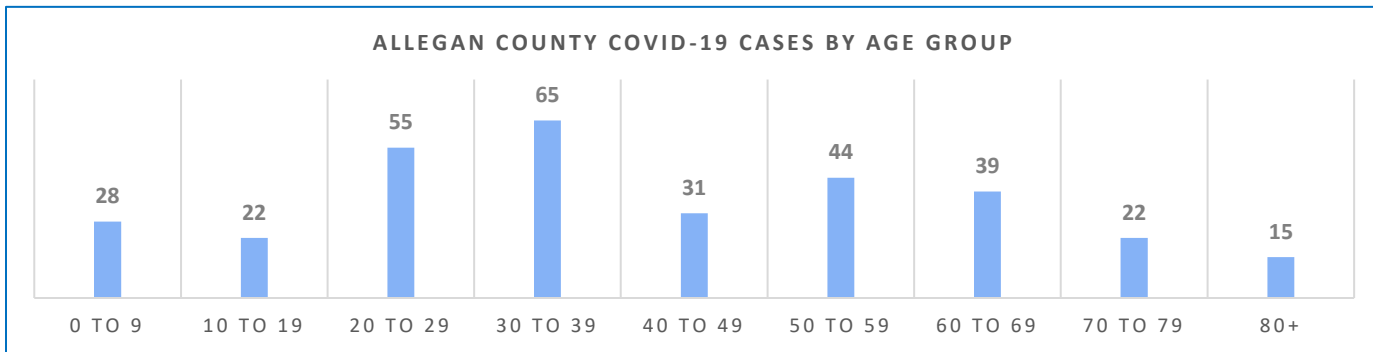

¹ COVID-19 may not be a primary cause of hospitalization in some of the reported cases in MDSS due to current capacity and data limitations; these data reported in MDSS are often limited by factors such as delayed case investigations and data back-filling

² As reported in the MI-HAN Regional Data File; Positivity Rate is calculated for percent positive persons for day and county

³ Case investigation consists of contacting the individual and asking standard questions related to the disease and identifying those who might have been exposed.

From 8/19/2022 to 9/1/22 in MDSS: 18.4% of cases were reported in the 30 to 39 age group, which had the highest number of cases and is similar to the current statewide case patterns. In comparison to the previous reporting period (8/5/22 to 8/18/22), case counts have decreased overall for all age groups, with an uptick in the 10 to 19 and 70 to 79 ages for the current timeframe.

- 4% of cases were in **quarantine** at the time of symptom onset or positive test
- 19.2% of investigated cases were **household close contacts**⁴
- 0.3% of cases were reported as **community contacts**⁵
- 6.8% of cases were close contacts to those who work or live in a **high-risk/congregate facility**

Notifying close contacts helps individuals know about exposure and allows close contacts to make decisions based on their own risk assessment.

323 cases were reported in the MDSS from 8/19/2022 to 9/1/22

EXPOSURE LETTERS AND CLOSE CONTACTS

ACHD sends potential Exposure Letters for COVID-19, similar to other communicable disease letters. Potential Exposure Letters are sent to school-aged individuals based on classroom and bus lists provided by schools.

17,117 exposure letters were sent from March 1, 2022, to September 5, 2022

1 close contact is currently being monitored as of September 5, 2022

OUTBREAKS & CLUSTERS IN ALLEGAN COUNTY

The following table shows the number of outbreaks⁶ that ACHD has identified for high-risk settings as of September 1, 2022. **ACHD has identified one new outbreak related to Long-Term Care Facilities⁷ and two new outbreaks related to Schools, since the last update on August 25, 2022;** there were **four** ongoing outbreaks reported to MDHHS as of September 1, 2022. ACHD has not identified any new outbreaks for businesses since February 17, 2022.

ACHD has developed COVID-19 Business Mitigation Strategies Survey for businesses, Long-Term Care Facilities, daycares and schools to provide us with information on the current mitigation strategies they have in place. The surveys are sent out when an outbreak has been identified at a location.

Type of Setting	Total Number of Outbreaks, since October 2021*
School	20
Business	8
Long Term Care ^β	30
Other Congregate Facilities ^α	3

*Includes clusters per requirement indicated in MDSS' outbreak investigation fields to assign an outbreak code for 'clusters'

^βIncludes Skilled Nursing Facilities (SNF), Adult Foster Care (AFC), Home For the Aged (HFA), Assisted Living, and Independent Living facilities

^αIncludes jails, correctional facilities, and shelters

LONG TERM CARE & OTHER CONGREGATE CARE FACILITIES

From January 2022 to September 5, 2022, ACHD has connected **19 LTCFs** in Allegan County with the iPRAT Team for additional mitigation assistance⁸.

⁴ Household contact: person lived with someone who tested positive and later tested positive themselves.

⁵ Community contact: person who was identified as a close contact in a setting other than a household

⁶ Outbreak investigation codes are assigned by the first date of onset

⁷ Data from 10/21/2021

⁸ An outbreak investigation is initiated when a resident at a Long-Term Care Facility (LTCF) is identified as a confirmed case of COVID-19. For correctional facilities, either a confirmed or a probable COVID-19 case will prompt an outbreak investigation. MDHHS offers further support for facilities via the Infection Prevention and Resource Assessment Team (iPRAT) when ACHD identifies facilities that are experiencing a large number of positive COVID-19 tests.

In Michigan, the number of LTCFs reporting three or more cases in a single reporting period is steadily **increasing** for both Adult Foster Care (AFC)/Home for the Aged (HFA) from 24 to 25, and Skilled Nursing Facilities (SNF) from 38 to 47, since the last Michigan Data and Modeling update on August 23, 2022. According to statewide data⁹, the case counts reported for residents and staff in AFC/HFA are currently **plateaued**. Case counts reported for residents and staff in SNFs, have **increased**. Cases within LTCFs continue to be higher among staff than among residents, which has been the case throughout the Delta and Omicron surges. **These values mirror the case counts for residents and staff of LTCFs in Allegan County.**

ACHD shares forecasting wastewater readings with long-term and congregate care facilities in the monthly LTCF Newsletters, to help inform their COVID-19 mitigation strategies.

565 resident cases and 55 resident deaths reported from January 1, 2020, to August 23, 2022¹⁰

869 staff cases have been reported from January 1, 2020, to August 23, 2022

SUFFICIENT HEALTH CARE CAPACITY

HOSPITALIZATIONS

Allegan County falls in the Region 5 Health Care Coalition. Some community members will also access hospitals in the Region 6 Health Care Coalition (Grand Rapids-Holland Region). The chart below lists the hospitals that Allegan County community members may access for COVID-19 and non-COVID-19-related health needs and their current capacity levels.

The following figures show the current percentage of inpatient beds treating COVID-19 patients, for the Grand Rapids Region (Region 6), and Kalamazoo Region (Region 5). The **Grand Rapids Region** had **4.7%** of inpatient beds that are COVID-19 positive, as of August 29, 2022, which is **0.3% higher** than the previous reporting period, August 9 to August 15. The **Kalamazoo Region** had **7.3%** of inpatient beds that are COVID-19 positive, as of August 29, 2022, which is **.6% lower** than the previous reporting period.

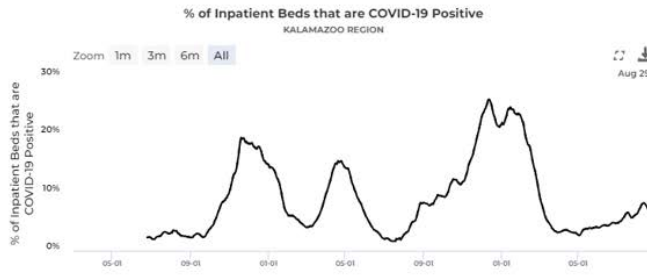
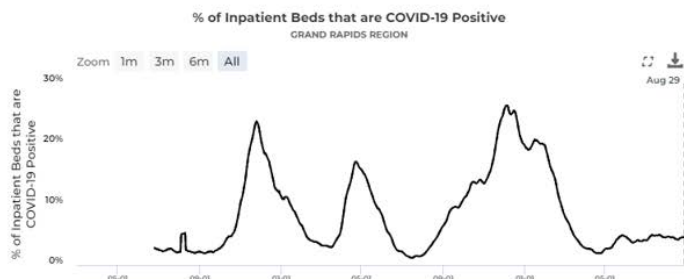

HOSPITALS IN THE ALLEGAN COUNTY AREA

See [previous report from 8/11/22](#) for updates regarding hospital bed capacity. Hospital bed capacity information can be found on the MDHHS website: [Statewide Available PPE and Bed Tracking \(Michigan.gov\)](#)

DEATHS (7 DAY AVERAGE)

Vaccinations have been shown to be effective at preventing deaths from COVID-19.

⁹ Weekly data reported by facilities with bed occupancy of at least 13 beds

¹⁰ The information above represents COVID-19 data reported directly to MDHHS by licensed and operating Skilled Nursing, Home for the Aged and Adult Foster Care facilities (licensed to serve 13 or more individuals) in Michigan from January 1, 2020, through August 23, 2022

The 7-day average for daily deaths is currently less than 1, and is relected as 0 on the Michigan Safe Start Map. For a complete view of the 7-day average daily deaths for Allegan and other counties over the course of the pandemic visit, [Dashboard | CDC | MI Start Map](#)

BEST PRACTICES

SCHOOLS

ACHD has updated our School COVID-19 Guidance documents as of August 26, 2022, to align with the changes CDC made to their COVID-19 recommendations on August 11, 2022. ACHD updated guidance documents can be view on our [School Resources COVID-19 page](#).

MONKEYPOX (MPV)

The CDC has released a new resource page answering frequently asked questions about monkeypox for administrators and staff of K-12 schools, early care and education (ECE) programs, camps, and other community settings serving children or adolescents. ECE programs may include center-based childcare, family childcare, Head Start, or other early learning, early intervention and preschool/pre-kindergarten programs delivered in schools, homes, or other community settings. This information may also be helpful to parents who have questions about monkeypox.

View the [CDC Monkeypox FAQ page](#).

BUSINESSES

No new COVID-19 updates for this section, please see the [previous report from August 25, 2022](#).

MONKEYPOX (MPV)

No new updates, please see the [previous report from August 25, 2022](#).

COMMUNICATIONS

COVID-19 Health Education has been a mandated service in this response. The following are metrics related to COVID communication efforts from 8/19/2022 – 9/1/2022:

- 4 Social media posts
- 9 Education materials created/updated
- 1 School and Childcare Update sent out
- 1 Long Term Care Update sent out

BIRD OWNERS ENCOURAGED TO CONTINUE PRACTICING BIOSECURITY MEASURES TO PROTECT BIRDS FROM HPAI

The Michigan Department of Agriculture and Rural Development (MDARD) has not reported any new cases of highly pathogenic avian influenza (HPAI) in domestic poultry flocks since May 2022, but the virus is still being detected in Michigan's wildlife. These detections added with the fall migration of wild birds means it is important to continue following biosecurity measures to help keep birds healthy.

The Michigan Department of Natural Resources regularly updates its [website](#) with the new cases found in wild birds and mammals.

The public health risk associated with this disease remains low according to the [U.S. Centers for Disease Control and Prevention](#). In addition, no birds or bird products infected with HPAI will enter the commercial food chain. As a reminder, people should [properly handle](#) and cook all poultry and eggs.

Data as of September 5, 2022

Following [a few key steps](#) is still important to help protect Michigan's domestic birds:

- Prevent contact between domestic and wild birds by bringing them indoors or ensuring their outdoor area is fully enclosed.
- Wash your hands before and after handling birds as well as when moving between different coops.
- Disinfect boots and other gear when moving between coops.
- Do not share equipment or other supplies between coops or other farms.
- [Cleaning and disinfecting](#) equipment and other supplies between uses. If it cannot be disinfected, discard it.
- Use well or municipal water as drinking water for birds.
- Keep poultry feed secure to ensure there is no contact between the feed/feed ingredients and wild birds or rodents.

Domestic bird owners and caretakers should watch for multiple sudden deaths in the flock, a drop in egg production, a significant decrease in water consumption, or an increase in sick birds.

- If avian influenza is suspected in domestic birds, contact MDARD immediately at 800-292-3939 (daytime) or 517-373-0440 (after-hours).

If anyone notices what appears to be unusual or unexplained deaths among wild bird populations, please report these cases to the Michigan Department of Natural Resources (DNR) by:

- Using the DNR's [Eyes in the Field app](#). Choose the "Diseased Wildlife" option among the selections for "Observation Forms."
- Calling the DNR Wildlife Disease Laboratory at 517-336-5030.

Subscribe to receive email notifications by visiting [MDARD's website](#) and clicking on the "Avian Influenza" link. After entering a valid email address, subscribers will receive updates and alerts regarding the status of avian influenza in Michigan whenever there are new developments to report. Additional resources can also be found at [Michigan.gov/BirdFlu](#).

More information on avian influenza and how to protect flocks through biosecurity measures can be found on the U.S. Department of Agriculture's [website](#).

COMMUNITY VACCINATION/HERD IMMUNITY/TREATMENT

UPDATED COVID-19 BIVALENT BOOSTERS FOR THOSE 12 YEARS OF AGE AND UP

On September 1, 2022, the CDC issued new recommendations for COVID-19 boosters, after the FDA authorized updated booster formulas from both Pfizer and Moderna. The CDC recommends that everyone who is eligible stay up-to-date on vaccinations by getting an updated booster dose at least 2 months after their last COVID-19 shot—either since their last booster dose, or since completing their primary series. **Pfizer's updated booster shot is recommended for individuals 12 and older, and Moderna's updated booster shot is recommended for adults 18 and older.**

These new boosters contain an updated bivalent formula that both boosts immunity against the original coronavirus strain and also protects against the newer Omicron variants that account for most of the current cases. Updated boosters are intended to provide optimal protection against the virus and address waning vaccine effectiveness over time.

Eligible individuals can get either the Pfizer or Moderna updated booster, regardless of whether their primary series or most recent dose was with Pfizer, Moderna, Novavax, or the Johnson & Johnson vaccine. **As per the CDC's recommendations, the new bivalent booster replaces the existing monovalent vaccine booster, therefore the monovalent vaccine will no longer be authorized for use as booster doses in people ages 12 and up.**

The Pfizer bivalent booster is currently authorized for ages **12 and older** while Moderna's is currently authorized for ages **18 and older**. Individuals may choose to receive either the Pfizer or the Moderna bivalent booster, regardless of which primary series vaccine or original booster dose they had previously.

ACHD anticipates starting to give these bivalent boosters within the next two weeks, and will provide further updates when available.

In the coming weeks, CDC also expects to recommend updated COVID-19 boosters for those under the age of 12, per the discussion and evaluation of the data by the Advisory Committee on Immunization Practices (ACIP) on Sept. 1, 2022. When more information

becomes available, ACHD will provide an update to the public. In the meantime, parents are encouraged to have their children complete the primary series of the current vaccines so that they will be eligible for the bivalent booster in the future. Parents of children under 12 are also encouraged to consider having their children receive the original booster at this time to increase their defenses against the virus with back to school and other group activities now occurring.

For more information, read the [full CDC press release](#) and [full FDA press release](#). Visit the [COVID-19 Bivalent Vaccine Boosters FDA page](#).

COVID-19 VACCINE COVERAGE

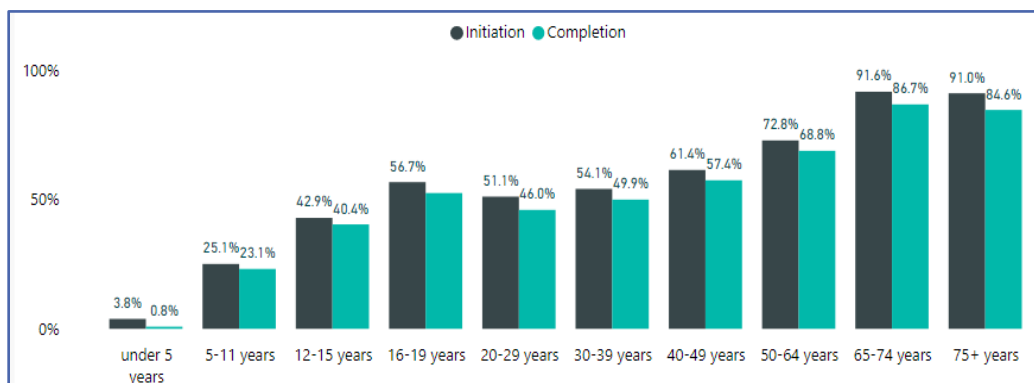

VACCINATION COVERAGE BY AGE GROUP

Data as of 9/2/2022

The adjacent map displays vaccine coverage for Allegan County. Vaccine rates for the age group 65+ are higher than overall state vaccine rates. See Previous Reports for updates on Vaccine Coverage [here](#).

VACCINATION COVERAGE BY ZIP CODE

The map on the left shows the vaccination rates for residents aged 16 and older who received at least one dose of vaccine. The data is at the census tract¹¹-level (colored sections) with an overlay of Allegan zip codes. This map gives more context for the parts community to focus on when organizing potential vaccination campaigns. Areas in the center of the county, with lower population counts, appear to have the lowest vaccination rates, while perimeter areas on the East and West sides of the county have higher vaccination rates overall. This data is based on a total population count of 115,250 as recorded in the 2018 US Census

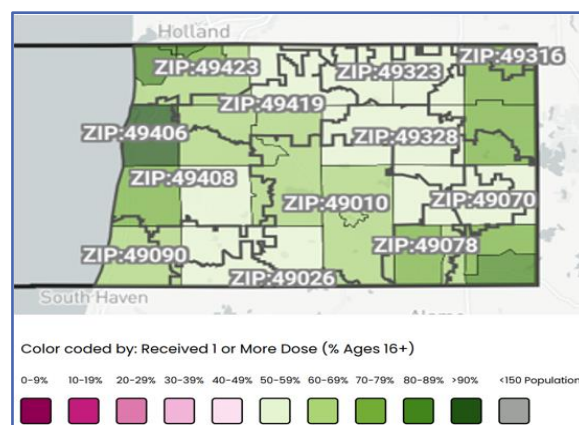

¹¹ Census tracts are geographic entities within counties with similar characteristics such as population traits, school enrollment, poverty level, median household income, housing vacancy, etc.

VACCINE AVAILABILITY

Vaccine availability remains high as pharmacies, doctor's offices, and health care systems are administering vaccines. ACHD has vaccine appointments available on Thursdays each week for vulnerable populations or children in the Vaccine for Children program.

Residents are encouraged to visit www.vaccinefinder.org and www.vaccinatewestmi.com to find vaccination clinics near them, or call ACHD at 269-673-5411 to schedule an appointment.

VACCINE EFFECTIVENESS (VE)

Current [data](#) continues to show that COVID-19 vaccines are **an important layer in reducing the severity of illness, and the burden of hospitalizations and deaths** in children, adolescents, and adults, **even with the emergence of the predominant new Omicron variants** such as BA.4 and BA.5.

Being [up to date](#) on COVID-19 vaccines is crucial in reducing the burden of hospitalizations and deaths. Please refer to key data takeaways from the [previous report](#) on studies conducted by the CDC's Breakthrough Surveillance Unit on Hospitalizations and Deaths associated with COVID-29, as of June 2022.

In Michigan, [data and modeling as of August 30, 2022](#) shows that **unvaccinated individuals 12 years and older had 6.1 times the risk of dying from COVID-19** compared to those who were up to date on the COVID-19 vaccination schedule. Please refer to the [updated CDC studies published in July 2022](#), as released on August 25, 2022 on the nationwide COVID-19 VE surveillance among adults:

Data Takeaway: The protection level of COVID-19 infection has waned across all age groups; protection is highest in adults who have received [all recommended vaccine doses](#).

BREAKTHROUGH SURVEILLANCE DATA: For more information and the latest data on the rates of COVID-19 breakthrough cases, hospitalizations, and deaths, please refer to [CDC COVID Data Tracker: Rates of COVID-19 Cases and Deaths by Vaccination Status](#)

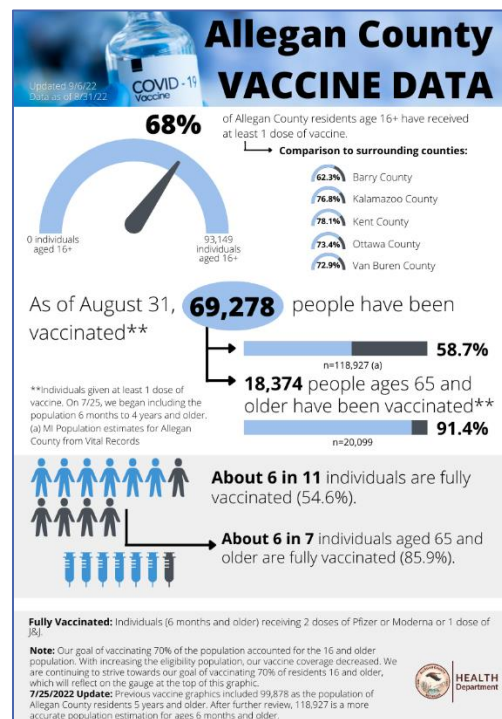

LOCAL HEALTH DEPARTMENT (LHD) BREAKTHROUGH DATA DISTRIBUTION

Refer to the [previous report from 6/21/22](#) for updates regarding breakthrough data distribution.

COVID-19 SURVEILLANCE

7-DAY METRICS ¹²	STATEWIDE	NATIONWIDE	GLOBAL
Cases	19,158	90,676	4.989 M
Hospital Admissions	151.43	5314	No data available
Deaths	129	390	15,474
Percent Population Fully Vaccinated	64.7%	67.4%	53.062 M ¹³
Percent Positivity	20-24.9 %	15.5%	No data available

STATEWIDE (MICHIGAN)

- As of **August 30, 2022**, [Michigan Coronavirus Data](#) reports a total of **2,770,359 cases** and **38,038 deaths** related to the SARS-CoV-2 infection.

¹² Statewide and Nationwide data as of 9/2/2022 [COVID Data Tracker Weekly Review | CDC](#); Global data update as of 8/28/2022 [COVID-19 Map - Johns Hopkins Coronavirus Resource Center \(jhu.edu\)](#)

¹³ This is not a percentage but a 7-day average of weekly doses administered globally

- Refer to the [August 30, 2022 MDHHS data and modeling](#) for current trends on cases, hospitalizations, and deaths associated with COVID-19.
- The **current R_t^{14} for Michigan has fallen slightly below 1**, thus indicating that **COVID spread is currently plateaued**.
- **11%** (9/83) of Michigan **counties** are at **High COVID-19 Community Levels** comprising of 31% of the population [as of August 25, 2022](#). Majority of the counties are at Medium or Low levels at present compared to the previous reporting week of August 15, 2022.
- Current statewide community levels are not as high as the first Omicron wave but are higher than the second Omicron (BA.2.12.1) wave that was around the months of April-May.
- Recent scenario hub projections suggest plateau or a smaller surge in the Fall and potential surge in the Winter. For more information regarding seasonal projections of cases, hospitalizations, and deaths, visit [COVID-19 Scenario Modeling Hub](#).

NATIONWIDE (UNITED STATES)

- Total **cases** nationwide as of September 1, 2022, is **94,385,669 (up 1,145,549 from August 19, 2022)**. **1,041,280 total deaths (up 8,327 from August 19, 2022)** have been reported as of September 1, 2022; which accounts for more than 15% of total deaths worldwide.
- According to the CDC, as of August 26, 2022, COVID-19 cases, deaths, and hospitalizations are **starting to plateau** after their rise in the summer, however, COVID-19 Community Levels for more than 72.4% of counties are still medium or high. Overall, 48 out of 52 jurisdictions (50 states, the District of Columbia, and U.S. territories) had counties with high or medium-level transmission week.
 - The District of Columbia, Massachusetts, Nevada, and Rhode Island are the only jurisdictions that have all counties at low Community Levels.
 - For the week ending in August 27, 2022, Omicron BA.5, the predominant variant, accounts for an estimated **88.7%** of new cases
 - Omicron variant BA.4.6, accounts for an estimated **7.5%** of cases
 - According to the CDC, the national proportion of lineages designated as omicron is 100%
- The 7-day average has decreased **6.7%** over the past week, which is slower than last week (data as of 8/30/2022)
 - As of August 30, 2022, the case rate was 186.8 cases/100,000 in last 7 days (week prior: 197.7 cases per/100,000)
- As of August 30 Nearly all Midwestern states (region 5) are showing signs of a plateau or decreases
- *29% of counties have high risk for medically significant disease and healthcare strain*

GLOBAL

- Globally, as of **September 1, 2022**, the World Health Organization (WHO) reports **600,555,262 confirmed cases (up 8,871,643 from August 19, 2022)** and **6,472,914 deaths (up 29,608 from August 19, 2022)** related to the SARS-CoV-2 infection.
- According to [WHO's weekly Epidemiological Situation Report](#) as of August 28, 2022:
 - Over 4.5 million new cases were reported globally during the week of August 22 to August 28 of 2022, and the **number of cases decreased by 16%** during this timeframe.
 - The overall number of **new weekly deaths decreased by 13%** with over 13,500 fatalities reported.
 - At the country level, the highest numbers of new weekly cases were reported from Japan (-15%), the Republic of Korea (-16%), U.S. (-10%), the Russian Federation (+23%), and Germany (-22%); the highest numbers of new weekly deaths were in U.S. (-6%), Japan (+23%), Brazil (-6%), Italy (-4%), and the Republic of Korea (+25%)
 - A comparison of global weekly sequencing of variants of concern between August 7 to August 20 of 2022 shows that BA.5 Omicron descendent lineages continue to be dominant globally, with an increase in weekly prevalence from 72.4% to 78.2%
 - BA.2.75 is currently an Omicron sub variant under monitoring, which continues to show a relatively low weekly prevalence globally

¹⁴ R_t is a unit of epidemiological unit of measurement to indicate the reproduction number of a virus over a particular time

- WHO conducts a routine assessment of variants of concern (VOCs), variants of interest (VOIs), and variants under monitoring (VUMs) in order to determine its risk posed to global public health. For more information on currently circulating variants and its classifications, visit [Tracking SARS-CoV-2 Variants](#)

WASTEWATER SURVEILLANCE

See the most recent [MDHHS data and modeling update](#) for the Michigan SWEEP Sentinel Wastewater Summary

Hope College has collaborated with ACHD to produce a dashboard, which displays the most recent wastewater readings and case counts. The colored circles of differing sizes represent the concentration of COVID-19 in the wastewater as of September 1, 2022 (TPA¹⁵, TPE¹⁶, TPP¹⁷), which have existing data points for the most recent nine calendar days (8/23/2022 – 9/1/2022).

The areas with red circles correlate with the increase in cases at LTCFs and other congregate care facilities during this reporting period. With this dashboard, ACHD has been able to forecast a rise in cases, which has improved mitigation responses. Since the last reporting period, **six** facilities around these treatment sites have reported 2+ COVID-19 cases.

The following three sites have the most current and accurate data readings:

Allegan Sewershed Sites	Trend Dates		Current Trend Patterns
TPA	9/1/2022	↔	Plateaued
TPE	9/1/2022	↗	Increasing
TPP	8/31/2022	↗	Increasing



The adjacent map shows current wastewater sewer shed sites that Hope College is monitoring in Allegan County

Key:

Red circles represent higher COVID-19 concentration levels
 Yellow circles represent lower concentration levels
 Green circles indicate virtually no COVID-19 detection

Read more about the [method of using wastewater surveillance data](#), to monitor case patterns at individual and population levels as it relates to the SARS-CoV-2 infection

EMERGING VARIANT UPDATES

- Omicron continues to be the predominant variant of concern (VOC) both globally and nationally, with several sub-lineages, including BA.4, BA.5, BA.2.12.1, and recombinants¹⁸ of these.
- The [CDC Nowcast Projections](#) (nationwide) estimate that the predominant Omicron sublineages BA.5 is projected at 88.7%, followed by BA.4.6 at 7.5%, BA.4 at 3.6%, and BA.2.12.1 at 0.2%. The combined national proportion of all Omicron lineages continues to be at 100% for the week ending on August 27, 2022. Refer to additional information on the CDC monitoring of nationwide variant proportions [here](#). For routine updates on the original Omicron lineage B.1.1.529 and its descendant lineages, refer to [Variants of the Virus | CDC](#).

Data Takeaways:

¹⁵ Allegan Water Resource Recovery Facility

¹⁶ Allegan/Perrigo East Lift Station

¹⁷ Plainwell Wastewater Treatment Plant

¹⁸ Recombinant occurs in "a process in which the genomes of two SARS-CoV2 variants (that have infected a person at the same time) combine during the viral replication process to form a new variant that is different from both parent lineages."

- The proportion of specimens sequenced and identified as BA.5 in the U.S. and Michigan continues to remain the most dominant.
- *Michigan*: Since July 15, there have been 2,649 VOC specimens sequenced of which 100% are of the Omicron lineage and 84% of the Omicron sublineage BA.5
- Data trends for the SARS-CoV-2 virus shows that some variant will emerge and disappear, while others will emerge and continue to spread and may replace previous variants.
- *Quick excerpts from the National Institutes of Health (NIH) on new technologies used for detection of emerging variants*:
 - Recent studies and data shows that BA.4 and BA.5 subvariants require a larger viral load to be detected on Antigen tests, thus, making it possible to produce pseudo-negative results.
 - NIH oversees the Rapid Acceleration of Diagnostics (RADx) program, which aims at advancing the current testing equipment utilized for detecting SARS-CoV-2 infection.
 - The RADx initiative collaborates with scientists and organizations' innovative methods in **an effort to minimize false negatives with the newer omicron sublineages**.
- ACHD continues to monitor all Omicron sub-lineages and deploy response measures accordingly.

EPIDEMIOLOGIC SURVEILLANCE

MONKEYPOX (MPV)

For background information on MPV and previous information discussed, refer to the [6/21/22 report](#).

UPDATES: As of September 1, 2022, MDHHS and the CDC's MPV Situation Summary has released the following data:

- **Michigan:**
 - 199 total MPV cases identified (which is up from 126 cases reported in the previous update)
- **United States:**
 - 19,465 total MPV/orthopoxvirus cases
 - California has the largest number of cases (n=3629) followed by New York (n=3367), Florida (n=1957), Texas (n=1698), Georgia (n=1418), and Illinois (n=1081)
- **Global:**
 - 52,090 cases in 100 countries (93 of these countries have not historically reported MPV cases)
 - The United States has the largest number of cases (n=19,464), followed by Spain (n=6,543), Brazil (n=4,876), France (n=3,547), Germany (n=3,480), and United Kingdom (n=3,279)
 - 15 total Deaths have been reported from Nigeria (n=4), Ghana (n=3), Spain (n=2), Central African Republic (n=2), Brazil (n=1), and Ecuador (n=1), India (n=1), and Cuba (n=1)
 - For a detailed list of the outbreaks reported in non-endemic countries, refer to: [Multi-country monkeypox outbreak in non-endemic countries \(who.int\)](#)

HIGHLY PATHOGENIC AVIAN INFLUENZA (HPAI)

No new updates; refer to [previous BOC updates on HPAI](#) and the section above on HPAI best practices in this report.

RECENT EMERGING HEALTH THREATS: AT A QUICK GLANCE

Adenovirus and Acute Hepatitis

- Updates according to situational report from WHO's Dr. Philippa Easterbrook:
 - First cases were reported in Scotland in early April 2022
 - More than 1000 cases from 35 countries worldwide
 - Distinctive feature is rapid progression and severity of liver disease in previously healthy children
 - Approximately 1/3 of cases went to the ICU, with 48 cases requiring a liver transplant
 - 18 deaths
 - No link to COVID vaccination

Data as of September 5, 2022

- **50-75% of all cases were positive for adenovirus. Two likely explanations:**
 - Children may have become more susceptible to adenovirus due to COVID restrictions - less exposure to many infections
 - 70% of children had evidence of past COVID infection which led to hyperactive immune response
- Majority of cases are children less than 5 years
- The World Health Organization has declared a moderate risk level for acute pediatric hepatitis. See the [previous BOC report from 7/12/22](#) and the [WHO Disease Outbreak News \(DONs\)](#) for updates on Adenovirus and Acute Hepatitis.

Arboviruses (Michigan Weekly Arbovirus Summary September 2, 2022)

- 18 mosquito pools positive for arbovirus infection
 - 3 human cases of West Nile Virus (WNV) or other arboviruses reported
- 12 mosquito pools from *Arenac, Genesee, Gladwin, Huron, Iosco and Kent counties* have tested positive for WNV
- 3 birds from Bay County, 1 bird from Saginaw, 1 bird from Shiawassee County, and 1 bird from Wayne have tested positive for WNV
- 6 mosquito pools from *Bay, Midland, and Saginaw counties* have tested positive for Jamestown Canyon Virus
- 1 mosquito pool from Saginaw County tested positive for LaCrosse (LAC) Encephalitis Virus
- One horse from St. Joseph County has died from Eastern Equine encephalitis (EEE)
- 3,345 mosquito Pools tested (50,317 mosquitos)
- Weekly Surveillance reports and the [Annual EZID Surveillance Summary for 2021](#) can be found at www.mi.gov/emergingdiseases

Rabies

- As of August 30, 2022, Rabies-positive animals in Michigan include **29 Bats** and **1 Skunk** from the following counties: Alcona (1), **Allegan (1)**, Bay (1), Delta (2), Huron (2), Kalamazoo (1), Kent (5), Oakland (2 bats and 1 skunk), Ottawa (2), Newaygo (1), Tuscola (2), Washtenaw (4), Ingham (1), Eaton (1), Shiawassee (1), Emmet (1), Berrien (1)

Salmonella Outbreaks Linked to Backyard Poultry

- No new updates; see the [previous BOC report from 8/25/22](#).

Salmonella Outbreaks Linked to Small Turtles

- As of August 31, 2022: 21 cases reported from 14 states (none in Michigan)
- 8 hospitalizations, 0 deaths
- Illness onset dates range: January 3, 2022 to July 15, 2022; the median age range for individuals that became ill is 14 years, and 60% of the individuals reporting ill are female
- Epidemiologic data shows of 9 cases interviewed, all 9 (100%) reported contact with a pet turtle with a shell < 4 inches long

Listeria Outbreaks Linked to Big Olaf Ice-cream

- No new updates, please see the [previous BOC report from 8/11/22](#).

Shiga toxin-producing Escherchia coli (STEC)

- As of September 1, 2022: 97 cases reported from 6 states (58 in Michigan)
- 43 hospitalizations, 0 deaths
- Illness onset dates range: July 26, 2022 to August 15, 2022; the median age range for individuals that became ill is now 22 years of age and 52% of the ill individuals are male
- Epidemiologic data shows of the 43 individuals hospitalized, 10 developed [hemolytic uremic syndrome](#)
- MDHHS issued a press release on August 16, 2022 regarding an increase in STEC infections across the state in addition to a MIHAN message sent late last week. For more information, see [MDARD guidance and recommendations](#)

SOURCES

- [Allegan County Health Department Facebook page](#)
- [American Academy of Pediatrics: Hepatitis Cases Possibly Associated with Adenoviral Infection](#)
- [American Community Survey 5-Year Data \(2009-2020\) \(census.gov\)](#)
- [Centers for Disease Control and Prevention](#)
- [CDC COVID-19 Booster Interactive Tool](#)
- [CDC COVID-19 Data Tracker](#)
- [CDC Recommends the First Updated COVID-19 Booster](#)
- [CDC Current Outbreak List | CDC](#)
- [CDC Health Alert Network](#)
- [CDC Provisional COVID-19 Deaths: Focus on Ages 0-18 Years](#)
- [CDC Stay Up-to-date on Vaccinations](#)
- [COVID-19 Bivalent Vaccine Boosters FDA page](#)
- [COVID Data Tracker Weekly Review](#)
- [COVID-19 Vaccine Dashboard](#)
- CHN Associates, Student, and Family Assistance Program Monthly Report
- [Division of Vector-Borne Diseases \(DVBD\) | Division of Vector-Borne Diseases | NCEZID | CDC](#)
- [FDA Authorizes Bivalent Booster Doses](#)
- [FDA: Investigations of Foodborne Illness Outbreaks](#)
- [Find a COVID-19 Vaccine Near You](#)
- [Hepatitis outbreak in children](#)
- HONU
- [Lighthouse \(mi-lighthouse.org\)](#)
- [Long Term Care Data](#)
- [MDHHS Monkeypox Page](#)
- [MDHHS School Outbreak Reporting](#)
- [MDHHS: School Age Case Data Dashboard](#)
- [MI Bridges](#)
- [MI COVID response Data and Modeling](#)
- [MI Weekly Arbovirus Summary, 2022 \(michigan.gov\)](#)
- [Michigan Coronavirus: COVID-19 Vaccine](#)
- [Michigan COVID-19 Wastewater Testing and SWEEP Dashboard](#)
- [Michigan Coronavirus Data](#)
- Michigan Department of Health and Human Services (MDHHS) Breakthrough Cases Data File
- Michigan Disease Surveillance System (MDSS)
- [Michigan DNR Eyes in the Field](#)
- Michigan Health Alert Network (MIHAN)
- [MI Safe Start Map and CDC Indicators](#)
- [New COVID-19 Cases Worldwide - Johns Hopkins Coronavirus Resource Center \(jhu.edu\)](#)
- [Office of International Health and Biodefense - United States Department of State](#)
- [Our World in Data - Coronavirus \(COVID-19\) Hospitalizations](#)
- [Previous BOC report from August 25, 2022](#)
- [Sewer Coronavirus Alert Network \(SCAN\) \(wastewaterscan.org\)](#)
- [Technical Report: Acute Hepatitis of Unknown Cause | CDC](#)
- [US Food and Drug Administration](#)
- [Vaccinate West Michigan](#)
- [World Health Organization Coronavirus Dashboard](#)
- <https://www.who.int/emergencies/diseases/novel-coronavirus-who> Coronavirus disease (COVID-19) Weekly Epidemiological Update and Weekly Operational Update2019/situation-reports

Allegan County COVID-19 Community Level: LOW

Allegan County Health Department recommends everyone to:

Stay up to date on your COVID-19 Vaccines

Get tested if you have symptoms, before and after traveling, and before gathering with others.

Actions including social distancing, frequent handwashing, wearing a well-fitted face mask, and isolation/quarantine help lessen the level of transmission. People may choose to mask at any time.

People with symptoms, a positive test, or exposure to someone with COVID-19 should wear a mask.



Learn more about CDC's COVID-19 Community Levels by visiting www.covid.cdc.gov

#DoYourPart

Allegan County COVID-19 Community Level: LOW

Pick-up Free Masks

- Monday-Friday 8:30am to 4:30pm at the Allegan County Health Department (3255 122nd Ave, Allegan)
- At select local units of government and libraries.
 - Visit allegancounty.org/covid to view the list of agencies under our Mask Information page.

Find COVID-19 Treatments

- Find information and options near you: michigan.gov/covid19therapy
- View a test to treat location near you: aspr.hhs.gov/TestToTreat
- Talk to your doctor about treatment options if you test positive for COVID-19.

Follow CDC's isolation and quarantine guidelines and stay home if you develop symptoms or test positive.

Get Tested:

- Order free at-home test kits online at:
 - www.covidtests.gov
 - www.accesscovidtests.org
- Pick-up test kits locally:
 - Visit www.allegancounty.org/covid to view pick-up locations under our Testing page.
- Find a community testing site near you at:
 - Allegan County Transportation Building (750 Airway Dr, Allegan) on Wednesdays and Fridays from 12 pm to 5 pm.
 - Visit www.solvehealth.com for more locations near you.

Stay up-to-date on COVID-19 Vaccines

- Find vaccine clinics near you at:
 - vaccinatewestmi.com
 - vaccines.gov
- Or call ACHD at 269-673-5411 to schedule an appointment



#DoYourPart

FREE AT-HOME TEST KITS FROM MDHHS AVAILABLE AT 2 LIBRARIES IN ALLEGAN COUNTY:

- Allegan District Library (331 Hubbard St, Allegan)
- Fennville District Library (400 W Main St, Fennville)

FREE COMMUNITY TESTING EVENTS ARE HELD EVERY WEDNESDAY AND FRIDAY AT THE ALLEGAN COUNTY TRANSPORTATION BUILDING FROM 12 PM – 5 PM. THESE EVENTS OFFER PCR AND RAPID TESTING OPTIONS.

VISIT THE [MDHHS COMMUNITY BASED POP-UP TESTING PAGE](#) TO SIGN UP FOR THE TESTING EVENTS AT ALLEGAN TRANSPORTATION BUILDING AND TO FIND OTHER TESTING SITES NEAR YOU.

Visit <https://www.solvehealth.com/covid-testing> to find additional COVID-19 sites near you.

COVID-19 testing location finder: [Coronavirus - Test](#)

If residents are struggling to find accessible testing, they can call ACHD at 269-673-5411 option 2 and we can help them navigate the systems.

MONKEYPOX: What to Know



How it spreads:

- Direct contact with the infectious rash, scabs, or body fluids
- Respiratory secretions during prolonged, face-to-face contact, or during intimate physical contact, such as kissing, cuddling, or sex
- Touching items (such as clothing or linens) that previously touched the infectious rash or body fluids
- Pregnant people can spread the virus to their fetus through the placenta

The illness typically lasts 2-4 weeks. People who do not have monkeypox symptoms cannot spread the virus to others.



Symptoms:

- Fever
- Headache
- Muscle aches and backaches
- Chills
- Exhaustion
- Swollen lymph nodes
- A rash that can look like pimples or blisters

Prevention:

- Avoid close, skin-to-skin contact with people who have a rash that looks like monkeypox.
- Do not touch the rash or scabs of a person with monkeypox.
- Do not kiss, hug, cuddle or have sex with someone with monkeypox.



- Do not share eating utensils or cups with a person with monkeypox.
- Do not handle or touch the bedding, towels, or clothing of a person with monkeypox.
- Wash your hands often with soap and water or use an alcohol-based hand sanitizer

If you feel sick or have symptoms, do not attend any gathering, and contact your healthcare provider.

Environmental Health - Benchmark Data Board of Commissioner Report



	January		February		March		April		May		June		July		August		September		October		November		December	
Total Applications Received for the Month	135		166		186		202		180		208		157		164									
14 Business Days for the Month are Permits received during	12/23 thru 1/7	1/8 thru 1/23	1/24 thru 2/6	2/7 thru 2/18	2/19 thru 3/13	3/14 thru 3/27	3/28 thru 4/10	4/11 thru 4/24	4/25 thru 5/8	5/9 thru 5/20	5/21 thru 6/12	6/13 thru 6/24	6/25 thru 7/10	7/11 thru 7/24	7/25 thru 8/7									
Incomplete and/or Unpaid Submissions within 14 Business Days	5	5	14	19	18	8	9	26	5	10	29	8	19	16	11									
Total Eligible for Completion within 14 business day window	37	31	62	79	91	62	81	81	65	69	122	65	54	57	74									
Submissions Not Completed within Eligible Time Period	2	0	0	1	0	0	2	2	0	1	4	2	0	2	1									
Total Completed	35	31	62	78	91	62	79	79	65	68	118	63	54	55	73									
Percentage Complete	95%	100%	100%	99%	100%	100%	98%	98%	100%	99%	97%	97%	100%	96%	99%									

Applications completed prior to 14 day turnaround (only those with proper documentation and fees paid): **Total Completed divided by Total Eligible for Completion within 14 business day window = Percentage Complete**

Number	Percentage
73/74	99%

14 business days from July 25 - August 7

	January		February		March		April		May		June		July		August		September		October		November		December	
Total Applications Received	135		166		186		202		180		208		157		164									
5 Business Days for Communication	1/10 thru 1/23	1/24 thru 2/6	2/7 thru 2/18	2/19 thru 3/6	3/7 thru 3/27	3/28 thru 4/10	4/11 thru 4/24	4/25 thru 5/8	5/9 thru 5/22	5/23 thru 6/5	6/6 thru 6/26	6/27 thru 7/10	7/11 thru 7/24	7/25 thru 8/7	8/8 thru 8/21									
Total Eligible for Communication	36	76	98	73	103	90	107	79	79	80	143	73	84	85	85									
Total Not Communicated to within 5 Business Days	1	0	2	0	0	0	0	0	1	0	0	0	0	0	2									
Total Communicated to within 5 Business Days	35	76	96	73	103	90	107	79	78	80	143	73	84	85	83									
Percentage Complete	97%	100%	98%	100%	100%	100%	100%	100%	99%	100%	100%	100%	100%	100%	98%									

Customers that have been contacted within 5 business days: **Total Communicated to within 5 Business Days divided by Total Eligible for Communication**

Number	Percentage
83/85	98%

5 business days from August 7 - August 21

Environmental Health - Total Services

Board of Commissioner Monthly Report



APPLICATIONS RECEIVED

	January	February	March	April	May	June	July	August	September	October	November	December	YTD Total
Well	40	45	52	54	37	58	48	53					387
Septic	32	56	53	68	46	54	42	47					398
Loan Eval.	7	13	7	17	11	11	12	9					87
MDHHS Eval.	5	7	3	6	5	8	9	5					48
SESC	36	26	47	46	57	51	34	40					337
Raw Land/Soil Eval.	15	19	21	8	21	22	10	9					125
Investigative Fieldwork	0	0	3	3	3	4	2	1					16
Monthly Totals	135	166	186	202	180	208	157	164	0	0	0	0	1398

SERVICES PROVIDED

PERMITS ISSUED	January	February	March	April	May	June	July	August	September	October	November	December	YTD Total
Well	37	37	52	46	34	62	54	49					371
Septic	36	40	63	45	51	60	54	42					391
Loan Eval.	3	13	11	5	7	13	8	10					70
MDHHS	5	7	5	2	7	4	7	7					74
SESC	31	38	35	40	40	43	37	39					303
Raw Land/ Soil Eval.	11	17	13	8	13	16	11	4					93
Monthly Totals	123	152	179	146	152	198	171	151	0	0	0	0	1272

Other Services Completed	January	February	March	April	May	June	July	August	September	October	November	December	YTD Total
Well Finals	87	85	29	40	18	11	8	21					299
Septic Finals	21	14	29	34	37	28	42	39					244
SESC Inspections	10	14	14	173	267	259	247	204					1188
Investigative Fieldwork	0	0	3	3	3	4	2	1					16
Monthly Totals	118	113	75	250	325	302	299	265	0	0	0	0	1747

Total Services Provided	241	265	254	396	477	500	470	416	0	0	0	0	6038
--------------------------------	------------	------------	------------	------------	------------	------------	------------	------------	----------	----------	----------	----------	-------------

Reports & Communications:

A. DDA/BRA/TIFA – Hick’s Park Sound System

The DDA/BRA/TIFA board recommends purchasing a sound system for Hick’s Park to use during special events. Three quotes were received and Community Development Manager Siegel recommends using BC Sound as they are local, visited the site to assess the needs of the park, and the quote includes the installation and training. The DDA/BRA/TIFA budget includes \$15,000 in the capital purchase line item to cover the cost of this system.

Recommended action: Consider approving a contract with BC Sound for a sound system in Hick’s Park in the amount of \$8,368.97.

B. WR – 12th St Lift Station Pump Purchase

The 12th St Lift Station has had repeated issues with clogged pumps requiring service calls for several years. Superintendent Pond believes a chopper cutter style pump will alleviate this issue and eliminate the service calls. Otsego Township will be most affected by this purchase, and the Township Board approved the purchase on September 12, 2022.

Recommended action: Consider approving a contract with JGM Valve for the purchase of two new pumps for the 12th St Lift Station in the amount of \$35,698.00.

C. DPW – City Tree Removal

There are certain trees throughout the city that Superintendent Nieuwenhuis has determined are dangerous and need to be removed. Three vendors were contacted for quotes but only Blankenship Logging had access to the necessary equipment to safely remove the trees.

Recommended action: Consider approving a contract with Blankenship Logging to remove city trees in the amount of \$16,600.00.

D. Resolution 2022-17 – Approved Depositories for 2022

Annually, the listing of approved depositories is reviewed. This year, the changes include banking changes and updates to the signatories for the accounts based on staffing changes.

Recommended action: Consider adopting the resolution as presented.

Reminder of Upcoming Meetings

- October 5, 2022 – Plainwell Planning – 7:00pm
- **October 10, 2022 – Plainwell City Council – 7:00pm**
- October 11, 2022 – Plainwell DDA/BRA/TIFA – 7:30am
- October 13, 2022 – Plainwell Parks & Trees – 5:00pm

Non-Agenda Items / Materials Transmitted

- Allegan County Board of Commissioners Update Administrator’s Report – September 8, 2022